

AXIOM® Knife Edge Perimeter Trim

Installation Instructions

1 GENERAL

1.1 Description

Axiom Knife Edge is a perimeter trim system designed for use with any of Armstrong's suspension systems. Field fabrication is limited to component assembly, straight cuts and minor adjustments to accommodate differences between design dimensions and actual field conditions.

Two versions of the product are available. AXKE2STR is designed for use with acoustical lay-in or tegular panels and drywall. AXKEV2STR is for use with full panel installations of the Vector® family of products.

These instructions are divided into five sections detailing material delivery and identification, component assembly, AXKE2STR Installation, AXKEV2STR installation and final detailing. Please carefully review all appropriate sections before proceeding with installation.

2 MATERIAL DELIVERY AND IDENTIFICATION

2.1 Delivery

Axiom Knife Edge components and hardware are delivered to the job site in custom designed packaging. Exercise appropriate care to protect the finished surfaces of the channel trim.

2.2 Review

Review the packing slip to insure that the complete order has been delivered to the site.

3 COMPONENT ASSEMBLY

3.1 Splice Plates and Alignment Clips

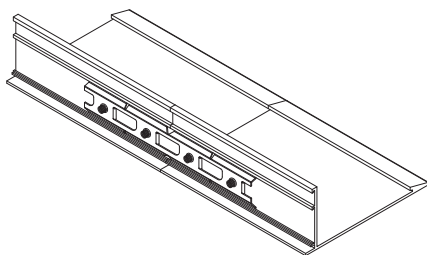

AX4SPLICEB – Splice Plate

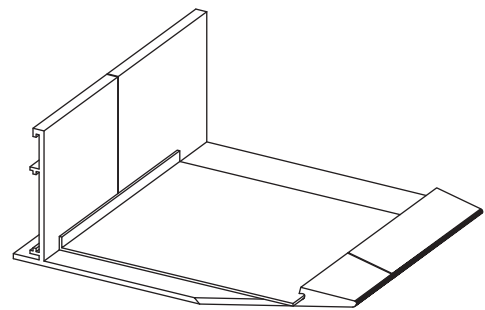

AXKEALIGN – Alignment Plate

Steel splice plates are used to align and secure all joints between sections of Axiom Knife Edge trim. Alignment clips serve to position the outer edges of the trim sections. Each joint will require one splice plate and one alignment clip. Splice plates are secured to the trim sections using factory-installed setscrews. Where desired, it may be beneficial to caulk or tape the backside of the vertical joints to prevent light transmission.

Typical procedure

- 3.1.1 Position the splice plate (AX4SPLICEB) so that it is roughly centered on the joint between trim sections.
- 3.1.2 Tighten the four setscrews to secure the splice to the trim. **CAUTION:** do not over tighten these screws to the point where they distort the face of the trim.
- 3.1.3 Install the Alignment Clip (AXKEALIGN) by inserting the flat end into the groove located behind the leading edge of the trim. Press the back end of the clip down to lock in position.

3.2 Corner Assembly

Factory assembled inside and outside corners come pre-mitered, bonded and finished. The legs of the corner measure 12" along the edge of the flange that supports the suspension system. Corner sections are installed using AX4SPLICEB splice plates and Alignment clips (AXKEALIGN) at each joint.

3.3 T-Bar Connection Clips – suspended ceilings

T-Bar Connection Clips are used to attach the Axiom Knife Edge trim to the supporting suspension system members. These two-piece clips are supplied as an assembled unit with the steel locking screw factory installed. One clip is required at each location where the grid system intersects the channel trim.

Note: For installation of T-Bar Connection Clips in drywall applications refer to the Drywall Trim Section.

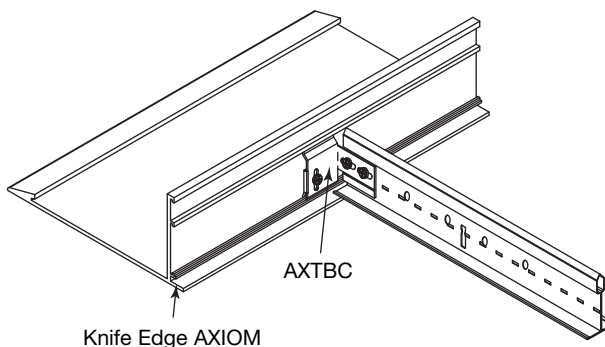

AXTBC – T-Bar Connector Clip

T-Bar Connection Clips are attached to the grid members using screws supplied by the installer. Framing screws (#6 x 7/16" or 1/2" lg.) are typical. Special conditions such as open cell installations may dictate the use of alternate methods of attachment.

See detail drawings, (page 3) for alignment of the connection clip with the grid member.

Typical procedure - Suspended Ceiling Installations

- 3.3.1 Cut grid to length
- 3.3.2 Attach clip to grid member
- 3.3.3 Engage clip in channel bosses and tighten locking screw

3.4 Drywall Trim

Drywall trim is used to finish the edges of gypsum panels that are applied to drywall grid finished with Axiom Knife Edge trim. Axiom drywall trim sections are factory formed to fit into the groove inside Axiom Knife Edge.

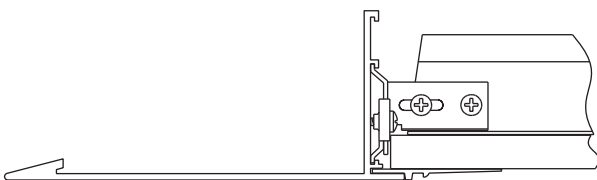

AXDWT in AXKE2STR – Knife Edge with Drywall Bottom Trim

Axiom drywall trim is set in place then fastened using standard drywall screws applied through the tapping flange of the trim into the drywall suspension system.

After installation the trim is finished using standard drywall materials and techniques. Normally, the drywall and Axiom Knife Edge is then painted to meet job requirements.

3.5 T-Bar Connector Clip Installation – Drywall

IMPORTANT NOTE: Use only the AX-V-TBC T-Bar Connector Clip for drywall applications.

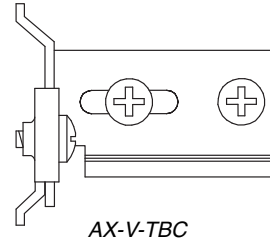

AX-V-TBC

- 3.5.1 Cut the clip off 1/16" above the score line for application of 1/2" drywall. Cut 3/16" above the score line (half way between the score line and the bottom of the screw slots) when using 5/8" drywall.
- 3.5.2 Attach the modified AX-V-TBC clips to the drywall grid system using two framing screws for each clip.
- 3.5.3 Install the Axiom Knife Edge trim and tighten clamping screws.

Typical Procedure - Drywall Applications

- 3.5.4 Install drywall suspension system and Axiom Knife Edge trim
- 3.5.5 Attach drywall to the system
- 3.5.6 Install Axiom Drywall Trim
- 3.5.7 Tape and finish drywall
- 3.5.8 Paint
- 3.6 Hold Down Clip for Metal Panels
 - 3.6.1 Use the AXSPTHDC clip to hold the face of cut metal panels down on the flange of the Axiom trim.
 - 3.6.2 One clip will be required for about every foot of cut panel edge.
 - 3.6.3 Insert the top of the clip into the Axiom trim first, then press up on the clip and engage the lower end.

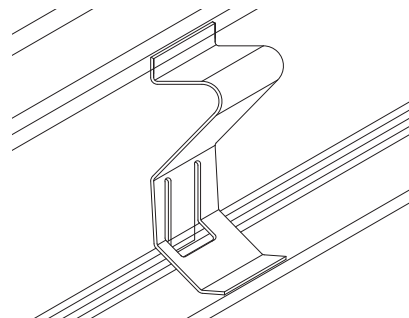

AXSPTHDC – Hold Down Clip

4 GENERAL INSTALLATION PROCEDURES

4.1 Layout and install the suspension system according to the reflected ceiling plan.

- 4.1.1 Plan your grid layout to maximize the length of cross tees that will support Axiom Knife Edge components.
- 4.1.2 Suspend the system using minimum 12 gage steel wire spaced no more than four feet on center along the mains. Additional wires may be required within eight inches of the cut ends of all grid components in areas where severe seismic activity is possible.

4.2 Brace and square the suspension system.

- 4.2.1 Although not absolutely necessary, bracing will greatly increase the speed and accuracy of completing the remainder of the installation, and is highly recommended.
- 4.2.2 The grid system can be braced diagonally to the structure above using either splayed wires, or rigid bracing members such as angles or cold rolled channels. In either case, install bracing in the plane of both main beams, and cross tees.
- 4.2.3 Squaring can be accomplished by temporarily clamping a rigid member (main beam or wall angle) diagonally across the topside of the grid system to maintain 90° alignment of the mains and tees.
- 4.2.4 An alternate method is to cut scrap grid components to fit diagonally into the ceiling module. When installed in pairs, these short braces are effective during layout and installation, and can be reinstalled on top of the ceiling panels to maintain alignment of the system.
- 4.2.5 For small installations, it may be preferable to assemble, mark and cut the suspension system components on the floor, and then to suspend and brace the grid system.

4.3 Assemble and position the Axiom components on top of the suspension system.

- 4.3.1 Temporarily assemble the Axiom components resting on top of the grid system. Check alignment and clamp the components in place.
- 4.3.2 Mark the location where the open side of the Axiom trim rests on the grid members. This mark will be used for initial alignment of the T-Bar Connection Clip.

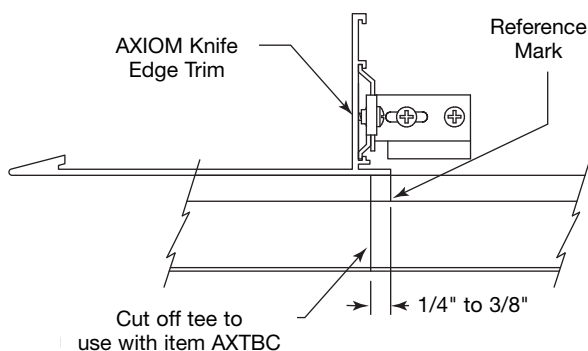

- 4.3.3 Make a second mark approx. 1/4" closer to the face of the Axiom trim. This second mark is where the grid members will be cut.

- 4.3.4 Remove the Axiom components and cut the grid members as marked.

- 4.3.5 Follow these guidelines for vertical location of the clips on the web of the grid members:

1. T-Bar grid that will rest on the lower flange of the Axiom trim

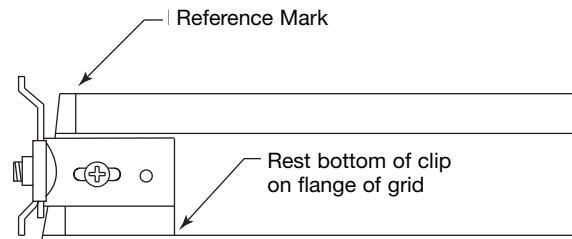

2. Silhouette, Interlude, Sonata and Trimlok (Systems with a 5/16" shoulder height) & 5/8" concealed tile on Prelude grid.

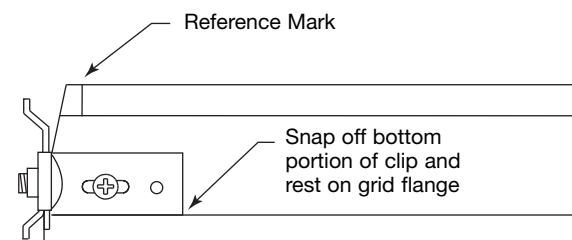

3. Metalworks Vector (cut panels) and 3/4" concealed tile

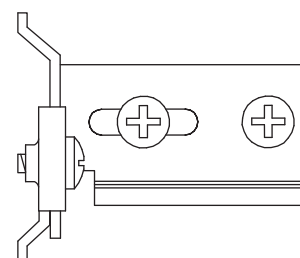

AX-V-TBC

4. Ultima, Optima and Woodworks Vector (cut panels)

- 4.3.6 Attach the clips by aligning the end of the elongated hole with the reference mark on the grid and inserting a standard framing screw into the center of the slot.

4.4 Install the Axiom Trim

- 4.4.1 Hang the sections of channel trim onto the grid system by engaging the top ear of the connection clips under the boss of the channel trim. Slide the back plate downward to engage the lower boss on the trim and secure by tightening the locking screw.

- 4.4.2 Complete the installation of all channel trim sections. Install and secure the splices and alignment plates.
- 4.4.3 Make adjustments as necessary to properly align the complete installation. Insert a second framing screw in each of the connection clips.

4.5 Add additional hanger wires as required.

- 4.5.1 The manufacturer requires that Axiom systems and their supporting suspension systems be installed and supported in a manner that complies to all applicable codes and standards. Typically this will require the use of #12 Ga. Galvanized, soft annealed steel wire, or equivalent. Specification and approval of alternate materials should be by design professionals familiar with the project. Mechanics should exercise care in the application of hangers to minimize the visual impact on the finished installation. Wire wraps should be tight and neat, and where appropriate, the wires may be painted to blend into the background as much as possible.
- 4.5.2 Main beams must be supported 4' on center or by calculation based on actual ceiling weight.
- 4.5.3 Cross tees located on each side of a joint in the channel trim and then at 4' centers must be supported by wires located closer to the trim than their midpoint.
- 4.5.4 Installations in areas requiring seismic restraint must have wires attached to each grid member within 8" of the cut end. Lateral force bracing shall be consistent with locally approved standards, or as detailed in the specifications.
- 4.5.5 Two hanger wires connected to Hanging Clips (AX2HGC) must support each section of Axiom Knife Edge trim. One hanging clip and wire is required for each welded corner.

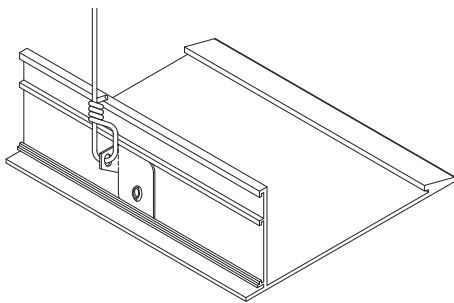

AX2HGC – Hanging Clip

- 4.6.1 Cut and install tiles or panels using standard procedures for the specified products.
- 4.6.2 Treat exposed cut edges of ceiling panels as detailed in the project specifications.

5 Axiom Knife Edge for Vector

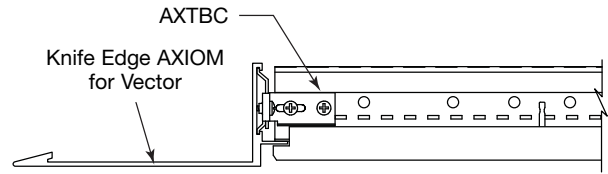

Knife Edge for Vector

- 5.1 Axiom Knife Edge for Vector is only appropriate for square or rectangular applications that feature all full size panels.
- 5.2 Cut and install the grid to maintain precisely 23-1/16" between the outer edge of the 15/16" T-bar grid and the inner edge of the Axiom Trim.
- 5.3 The correct length for the Axiom trim, when measured along the inside edge, will be 15/16" less than the nominal dimension of the full panel installation.

EXAMPLE: The nominal dimension of a four panel wide cloud would be 96". The Axiom trim should be cut to 95-1/16" measured along the inside edge of the flange that supports the grid.
- 5.4 Use standard AXTBC clips to attach the trim to the suspension system.
- 5.5 Brace the grid to structure as required by local codes and to maintain straight and square alignment.

6 Final Detailing

- 6.1 Check and adjust the alignment of Axiom components and ceiling panels.
- 6.2 Clean exposed surfaces as required. Painted Axiom components may be wiped down with a mild household cleaner to remove fingerprints, oil, etc.
- 6.3 Touch up painted components as required.
- 6.4 Axiom components with drywall are typically painted after assembly, taping and finishing.
- 6.5 For light cove applications a white latex chalk or tape should be applied to the inside of all seams if light leaks are apparent.



Mixed Sources
Product group from well-managed
forests, controlled sources and
recycled wood or fiber
www.fsc.org Cert. No. SML-COC-003348
© 1996 Forest Stewardship Council



panels, tile or drywall
Printed on recyclable paper
with vegetable-based inks.
Please Recycle.

MORE INFORMATION

For more information, or for an Armstrong representative, call 1 877 ARMSTRONG.
For complete technical information, detail drawings, CAD design assistance, installation information and many other technical services, call TechLine™ services at 1 877 ARMSTRONG or FAX 1 800 572 TECH.
For the latest product selection and specification data, visit armstrong.com/ceilings.
U.S. Patents Pending, including US Publication No. 2004/0182022.

