

METALWORKS™ PLANK

Installation Instructions

1. DESCRIPTION

- 1.1. METALWORKS Plank is a ceiling system made up of standard sized hook-on planks fabricated from galvanized steel and powder coated to provide a damage and soil resistant scrubbable finish. Panels are available in two sizes, 16" x 72" and 16" x 96". Panels may be microperforated or unperforated.
- 1.2. Planks are supported by a suspension system made up of standard drywall mains and specially adapted hook-on cross tees.
- 1.3. Installations terminating at a wall interface are trimmed out with aluminum "F" or shadow "F" moldings, or with item #7835 "C" channel. Floating installations are trimmed with a specially designed extruded aluminum plank perimeter trim.

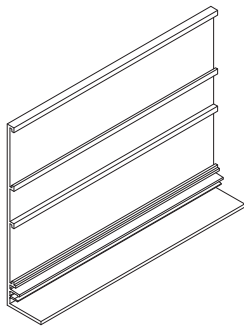

MetalWorks Plank
Perimeter Trim

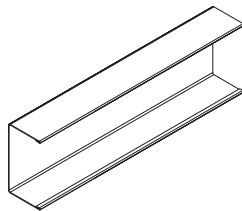

7835 C-Channel

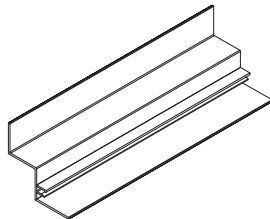

RA5F Shadow
Wall Molding

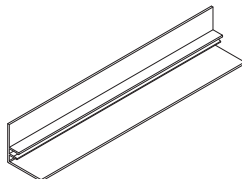

RA4F Wall Molding

2. SUSPENSION SYSTEM INSTALLATION

- 2.1. Read this entire document before proceeding with installation.
- 2.2. Layout of the suspension system shall be as detailed on the construction documents. Where panel layout is not defined, it shall be assumed that borders at opposite sides of the space will be equal and greater than 1/2 of the panel dimension in that direction.
- 2.3. The installation of the suspension system shall conform to local building codes and standards in all respects except as noted here in sections 2.3 and 2.4 and in section 5 of this document.
- 2.4. Standard drywall mains (item #HD8906) are to be installed 4' on center and supported by minimum 12 gage wire spaced at not more than 4' centers along the length of each main.
 - 2.4.1. When installation of hangers at spacing greater than 4' is desired, the installer shall contact Armstrong TechLine at 1-877-276-7876 to obtain allowable load information for the specific application. The caller shall be prepared to provide pertinent code information, a reflected ceiling plan and cut sheets for all ceiling mounted accessories.
- 2.5. Hook-on cross tees are to be installed in continuous rows spaced to match the length of the panels (72" or 96").
 - 2.5.1. It is important that the open side of the hook on all tees face in the same direction.

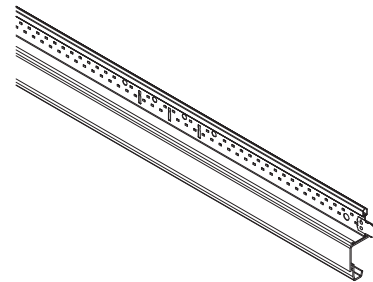

2.5.2. Standard 4' drywall tees may be required to provide support for light fixtures or other ceiling mounted accessories that are placed in panels. The weight of these components must be carried by the suspension system or by direct support to structure. They may not be supported by the ceiling plank.

3. PANEL INSTALLATION

3.1. Install full size panels by positioning the long hook end over the adjacent panel and placing the short hook end onto the Hook-on tee.

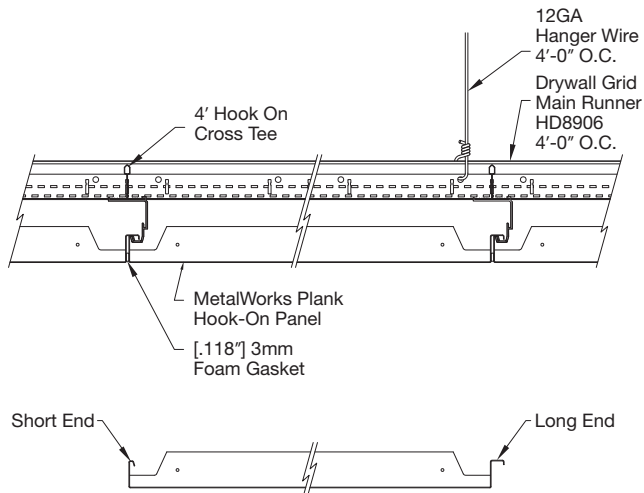

3.1.1. Pull a string line along the length of the ceiling and align the planks to this line.

3.2. A 1/8" thick gasket is provided on two sides of each panel. This space is required to allow access into the completed ceiling.

3.3. Panels are accessed by first raising the long hook end of the adjacent panel far enough to allow the short hook to disengage the hook-on tee.

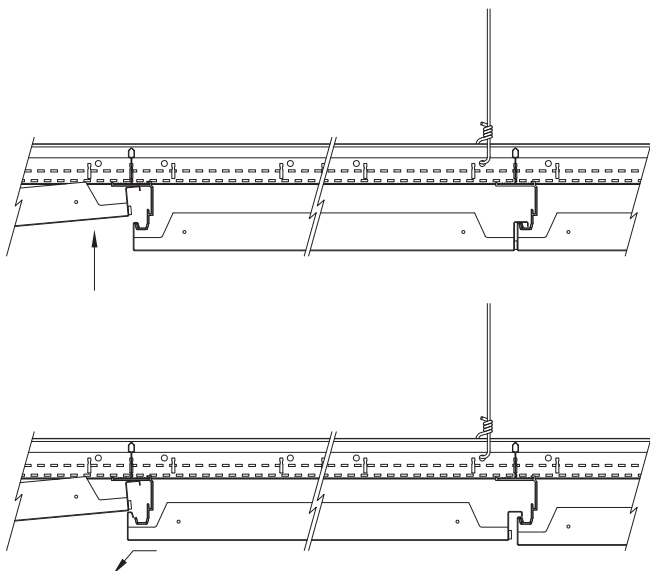

4. INSTALLING PRESSURE SPRING

Edges of cut panels are held in place on the extruded aluminum perimeter trims by inserting pressure springs into the groove provided in the perimeter trims.

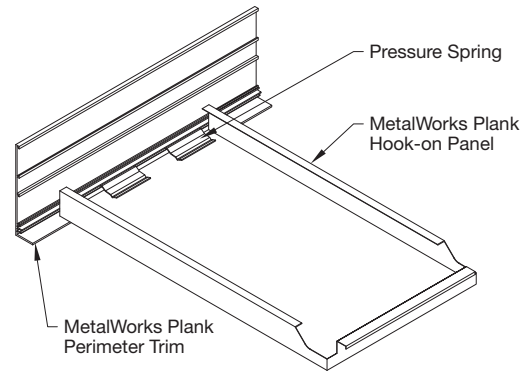

4.1. Install one pressure spring for each foot of panel edge, or as required to maintain contact between the panel edge and the trim flange.

4.2. Use spreader channel, item #7835SC, to retain cut panels when using the steel "C" channel at perimeters

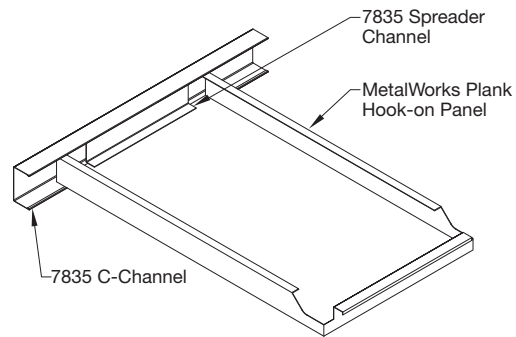

5. PERIMETER DETAILS

5.1. Installations terminating at a wall.

5.1.1. Attach the specified perimeter trim to the walls at the elevation detailed in the construction documents. This molding will support the face of the installed planks.

5.1.2. Install a second wall molding, item #7800, 2-13/16" above the horizontal flange of the first molding. This second molding will support the suspension system components.

5.1.3. Attach the main beams and hook-on cross tees to the upper molding by means of the BERC2 clip. This attachment will maintain the spacing of the grid at the walls. See additional requirements for seismic application of the BERC2 clip located in section 5 of this document.

5.1.3.1. Slip the BERC2 clip onto the cut ends of the mains.

5.1.3.2. Snap the BERC2 clip onto the vertical leg of the 7800 molding.

5.1.3.3. Pin the BERC2 clip to the molding by placing a screw through the molding and clip as shown.

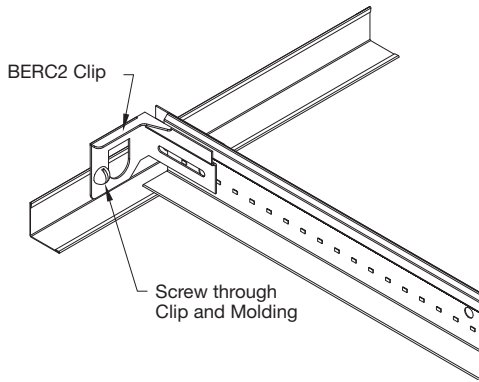

5.1.3.4. Cut the Hook-on cross tees to length.

5.1.3.5. Remove 1-1/2" of the aluminum extrusion by cutting with a hack saw.

5.1.3.6. Insert a screw through the aluminum hook and into the flange of the tee if there is not a rivet within 6" of the cut end of the tee.

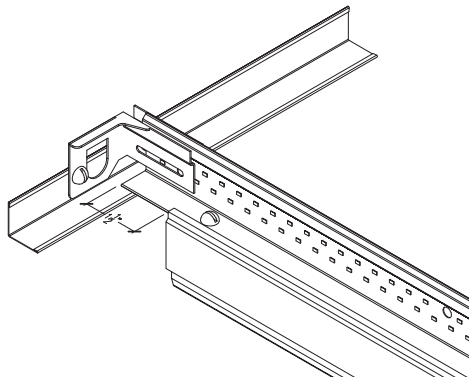

5.1.3.7. Slip BERC2 clip onto the cut tees. Install tees, align and pin to the molding as described in section 5.1.3.3.

5.2. Floating installations

5.2.1. Cut grid components to length and attach AXTBC clips as shown.

5.2.2. Attach additional hanger wires as required. Each end of each main beam must have a wire not more than 12" from the cut end.

5.2.3. Each cut cross tee must have a wire closer to the trim than the midpoint of the tee, but this wire may be no more than 12" from the end of the tee.

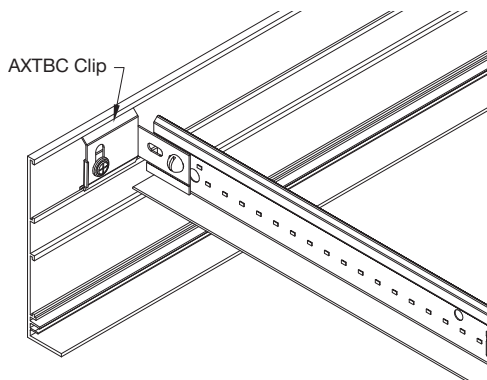

5.2.4. Cut the perimeter trim to length and miter corners.

5.2.5. Attach perimeter trim to the AXTBC clips on the suspension system components.

5.2.6. Join sections of perimeter trim with splice plates.

5.2.7. Splice plates that connect mitered sections of trim are field bent to the correct angle.

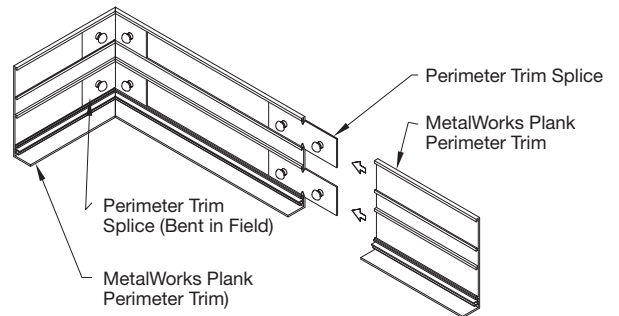

6. SEISMIC INSTALLATION

6.1. Follow these additional requirements for installations in areas subject to potentially severe seismic activity (IBC Seismic Design categories D, E & F).

6.2. Install additional rows of standard drywall cross tees (item # XL8945) between the rows of hook-on tees installed in section 2.5.

6.2.1. Installations with 72" panels will have tees spaced at 3' centers.

6.2.2. Installations of 96" panels will have tees spaced at 4' centers.

6.3. Attach one end of each row of mains and one end of each row of tees to the wall molding by replacing the BERC2 clip with a pop-rivet or by inserting a screw into the slot in the BERC2 clip.

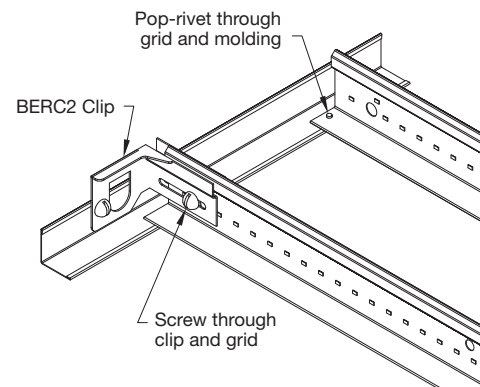

6.4. The opposite ends of each row of mains and tees must be cut 3/4" short of the wall and be free to slide in the BERC2 clip.

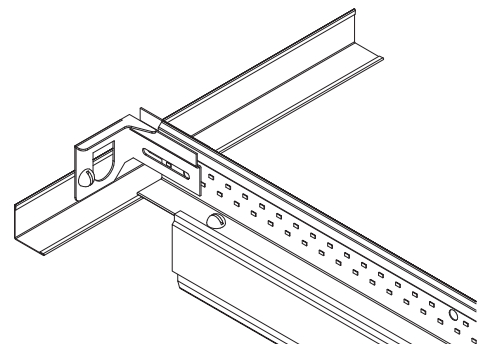

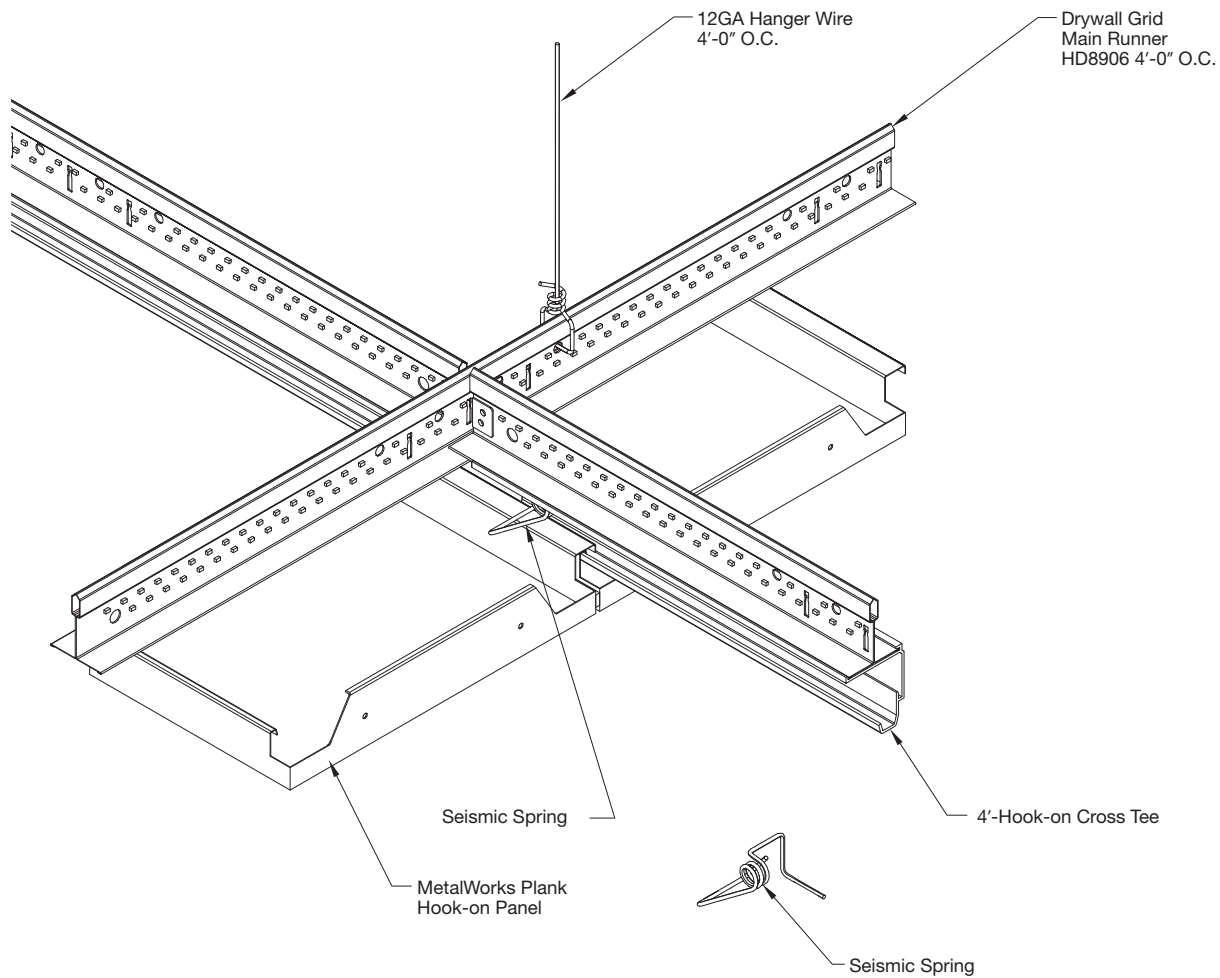

6.5. Install Seismic Springs (item #5337) as shown in the drawing above.

6.5.1. Turn spring in a clockwise direction to lock in the grooves formed in the hook-on tee.

6.5.2. Install one spring at each panel.

6.6. Follow all other building code requirements for seismic installation.

MORE INFORMATION

For more information, or for an Armstrong representative, call 1 877 ARMSTRONG.

For complete technical information, detail drawings, CAD design assistance, installation information and many other technical services, call TechLine™ services at 1 877 ARMSTRONG or FAX 1 800 572 TECH.

For the latest product selection and specification data, visit armstrong.com/ceilings.