

OPTIMA® and SPECTRA™ Capz™

Installation Instructions

For best installation results:

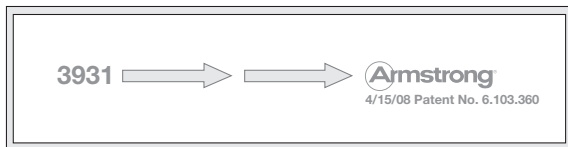

Panels are installation directional (refer to arrow on the back of panel). Arrows and text are larger than they appear on panels.

1. GENERAL

1.1. Product Description

Optima and Spectra Capz products referenced in these instructions are made from fiberglass. Optima and Spectra Capz panels are demountable, or 100% downward accessible. Panels are designed to be attached to a conventional 15/16" wide T-bar suspension system. All panels can be removed and re-installed without tools or special equipment for access to the plenum. Optima Capz panels are available in seven standard sizes: 24" x 48", 24" x 60", 24" x 72", 24" x 96", 36" x 36", 48" x 48", and 48" x 96". Spectra Capz panels are available in one standard size: 48" x 48".

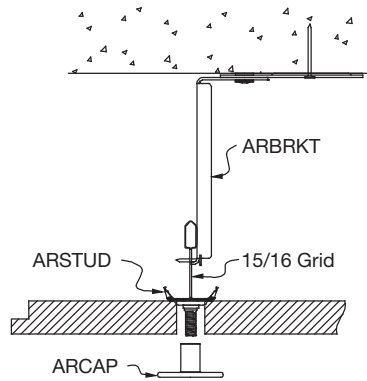

Optima and Spectra Capz panels have Reverse Tegular edges. Panels are pre-drilled to accept hardware caps. Hardware caps attach to threaded studs which clip onto the suspension system. Unlike many conventional lay-in ceiling products, the Optima and Spectra Capz edge detail does not lay into the suspension system.

1.2. Surface Finish

Optima Capz panels feature the Armstrong DuraBrite® finish. The surface of these panels is scratch and soil-resistant, highly light reflectant and washable. The panel edges are finished with a factory applied paint finish.

For minor surface or edge scratches on Optima Capz, use Armstrong SuperCoat™ Touch-up Paint Item #5761. Touch-up recommendations are provided later in this document (Section 6.7). SuperCoat Touch-up Paint data page is CS-3943.

Spectra Capz panels feature an acoustically transparent scrim. The panel surface and edges are finished with a factory applied paint.

1.3. Storage and Handling

The ceiling panels shall be stored in a dry interior location and shall remain in cartons prior to installation to avoid damage. The cartons shall be stored in a flat position. Proper care should be taken when handling to avoid damage or soiling.

NOTE: Optima and Spectra Capz panels feature exposed edges. Exercise appropriate care to avoid unnecessary contact or damage to the panel edges. Remember that the grid flanges will not conceal panel edge damage. Black paint on Spectra Capz can scuff or mar when handled. Please use caution when handling and installing Spectra Capz.

**1.3.1. Working With Fiberglass & Mineral Fiber Products
FIBERGLASS CEILINGS
MAN-MADE VITREOUS FIBER CEILING PANELS**

▲ WARNING THIS PRODUCT CONTAINS MAN-MADE VITREOUS FIBERS, A POSSIBLE CANCER AND RESPIRATORY TRACT HAZARD. CAN CAUSE TEMPORARY RESPIRATORY, SKIN AND EYE IRRITATION.

1.3.2. Precautionary Measures – During the installation be certain that the work site is well ventilated and avoid breathing dust. If high dust levels are anticipated during installation such as with the use of power tools, use appropriate NIOSH designated dust respirator. All power cutting tools must be equipped with dust collectors. Avoid contact with skin or eyes. Wear long-sleeved, loose-fitting clothes, gloves and eye protection.

1.3.3. First Aid Measures – If contact occurs flush eyes and skin irritation with plenty of water for at least 15 minutes and remove contaminated clothing. After installing material, wash with warm water and mild soap. Wash work clothes separately from other clothing. Rinse washer thoroughly. Refer to Armstrong MSDS (which includes information on established occupational exposure limits) which are available from Armstrong or your employer.

1.4. Site Conditions

Building areas to receive ceilings shall be free of construction dust and debris. These products are not recommended for exterior applications or where standing water is present or where moisture will come in direct contact with the ceiling.

1.5. Plenum

Installation of the Optima® and Spectra™ Capz™ system is within 6" of the structure. Design limitations require a clear plenum and are not suitable for plenum spaces crowded with services or obstructions.

1.6. Fire Sprinklers

Optima and Spectra Capz panels, as with other architectural features located at the ceiling, may obstruct or skew the planned fire sprinkler water distribution pattern, or possibly delay or accelerate the activation of the sprinkler or fire detection systems by channeling heat from a fire either toward or away from the device. Please consult a fire protection engineer, NFPA 13, and the local codes for guidance where automatic fire detection and suppression systems are present.

2. COMPONENTS

2.1. Grid

Optima and Spectra Capz installations use standard Prelude® 15/16" T-bar grid. Grid can be attached directly to the structure with rigid connectors or suspended with 12 ga. hanger wire.

2.2. Capz System Connectors

2.2.1. QSUTC is a rigid attachment clip to fasten the grid to structure.

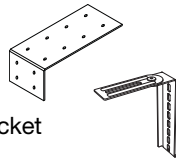

2.2.2. ARBRKT is an adjustable hanger bracket to fasten the grid to structure.

2.2.3. ARSTUD (1/4-20 threads x 1" long) is used to secure the Optima or Spectra Capz panel to the grid. The ARSTUD snaps onto the 15/16" Prelude T-bar grid at the required locations. Pre-drilled ceiling panels fit onto the ARSTUD.

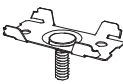

2.2.4. ARCAP screws through the panel onto the ARSTUD to align and support the panel. Caps are available in white, silver and black. Caps fit onto a 1/4-20 stud and have a 1-1/4" diameter face to support the panel.

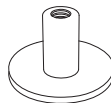

2.2.5. ARPLUG locks the cross tee tabs into the slot along the outside row of main beams of Optima and Spectra Capz installations. **NOTE:** ARPLUGs only work with Armstrong XL cross tee end details.

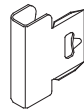

2.2.6. Panels – Optima Capz 7/8" panels are available in standard nominal sizes including: 2' x 4', 2' x 5', 2' x 6', 2' x 8', 3' x 3', 4' x 4' and 4' x 8'. Spectra Capz 7/8" panels are available in one standard nominal size: 4' x 4'. Panel edges are Reverse Tegular for a clean smooth visual when installed. Panels are pre-drilled with a 1/2" hole that easily fits over the ARSTUD.

3. REFLECTED CEILING PLAN

Refer to the reflected ceiling plan to determine the proper grid layout. Optima and Spectra Capz panels require grid above all pre-drilled holes in the panels.

3.1 Grid Layout

Grid layout uses standard main beams and cross tees. Main beams usually run the long direction of the installation. On-center spacing will be determined by the panel configuration. Cross tee length and spacing is also determined by the panel configuration. See grid layout example on page 5.

4. CAPZ GRID INSTALLATION

Optima and Spectra Capz suspension grid is attached directly to the structure with rigid brackets.

4.1. Grid Layout

Grid layout is very important for ease of panel fit, alignment and best visual. Refer to the reflected ceiling plan to determine the correct grid components and on-center spacing.

4.2. Brackets

Brackets are used to attach the main beam to structure. Brackets are recommended within 12" of the ends and not more than 48" on center along the run of main beams. Brackets allow grid elevation adjustment from 1-3/4" to 5-1/2". Use heavy snips or a hacksaw to trim the bracket for different heights or as needed to level the grid. Avoid installing bracket on the main beam at the location of cross tees.

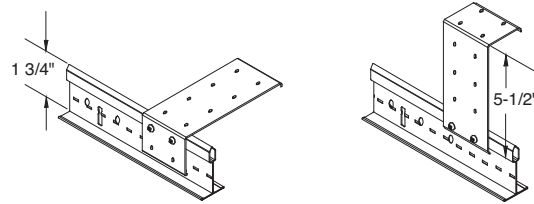

4.2.1. QSUTC – This clip must be accurately located before fastening to the structure for correct grid alignment and proper panel fit. Use a string line or laser to establish a straight row for bracket attachment. Use the appropriate fastener to anchor the clip to the structure.

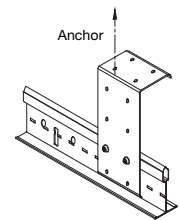

4.2.2. ARBRKT – This bracket is adjustable after fastening to the structure with a screw. This allows flexibility and minor variations for attachment to the structure. Use of a string line or laser is still recommended for this bracket. Grid can easily be aligned and squared for proper panel fit. Use the appropriate fastener to anchor the clip to the structure.

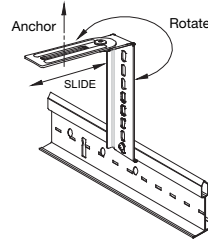

4.2.3. Hanger Wire – 12-gauge hanger wire can be used for Optima and Spectra Capz systems when the grid will be installed more than 5-1/2" below the structure. This suspended grid system must be installed to meet ASTM C636 standards and International Building Code seismic installations as required by local authority.

4.3. Install Grid

The grid must be installed straight, level and square for best panel fit and alignment. Optima and Spectra Capz panels require grid above all the pre-drilled mounting holes. It's best to have two holes per panel at a main beam/cross tee intersection to keep the panel in place but not required. Some Optima and Spectra Capz layout designs may have only every other panel with holes at a main beam/cross tee intersection. Optima and Spectra Capz panels cover or conceal most of the grid. Hangers and grid may be in the line of sight when installed at lower elevations. Consider using Prelude 15/16" T-bar grid in Tech Black with Spectra Capz. Components can be field painted to blend in with the plenum.

4.3.1. Main Beams – Mains must be attached to the bracket so that a cross tee slot is located at the hole locations of the panel per the reflected ceiling plan. Optima and Spectra Capz panels extend 6" past the mounting hole. Trim off the main beam end approximately 3" past the first and last cross tee location to keep the main beam concealed.

4.3.1.1. First Row of Main Beams – Use clamps or vise grips to temporarily secure the first main to the brackets. Adjust for proper location and elevation. Use two sheet metal screws (Type #8 x 1/2 sharp point screw) to fasten the bracket to the main beam. Use the typical method to join sections of main beams for long runs.

4.3.1.2. Additional Rows of Main Beams – Brackets should be installed accurately for the proper main beam spacing as per the reflected ceiling plan. Use clamps or vise grips to temporarily secure the second main to the brackets. Check for the correct on-center spacing for the cross tee; adjust if necessary. Install two cross tees at the proper location. **CHECK SYSTEM SQUARENESS** – this is a critical stage of grid installation. System squareness must be within 1/16". The system must be square or will result in improper panel fit, poor alignment, and an unacceptable visual. Measure diagonals, use a carpenter's square or the 3-4-5 method to square the system. Secure the second main beam to the brackets with sheet metal screws. Install additional main beams keeping the system straight and square.

4.3.2. Cross Tees – Refer to the reflected ceiling plan to determine the length and on-center spacing of the cross tees. Install the cross tees as required. Since the mains are secured with rigid brackets, you may need to roll the top bulb away to ease insertion of the cross tee clip.

4.3.2.1. ARPLUG – All the cross tees along the outside rows of main beams will have a single tab inserted into the cross tee slot. To secure and align this tab, insert the ARPLUG along the right side of the cross tee tab.

NOTE: ARPLUGs only work with Armstrong XL® cross tee end details. See ARPLUG detail in drawing on page 6.

5. INSTALL ARSTUD

Refer to the reflected ceiling plan for panel hole or stud locations. Optima® and Spectra™ Capz™ panels may have all studs at a main beam/cross tee intersection, a combination of studs at main beam/cross tee intersections and studs along the grid flange or on the grid flange only. ARSTUDs easily snap onto the grid flange. Make sure all four corner tabs lock onto the grid.

5.1. Grid Intersections

The ARSTUD fits over grid intersections and will secure the Optima or Spectra Capz panel for proper stud spacing and panel alignment.

5.2. Grid Flange

The ARSTUD fits anywhere along the grid flange as needed. Standard Optima and Spectra Capz panel stud locations are on 12" increments. Snap the ARSTUD onto the grid and slide it directly under a cross tee slot at the required spacing.

6. PANEL INSTALLATION AND CAPS

6.1. Panel Orientation

Install all Optima and Spectra Capz panels with the directional arrow in the same direction to provide installation consistency, uniform visual and proper panel alignment. Align panels as you proceed to ensure a uniform 1/4" reveal width between panels. Minor variations in panel placement can be difficult to see from a scaffold, but will become obvious when looking down long runs of panels. See detail in drawing on page 6.

6.2. Large Panels

The use of two installers is recommended for Optima Capz panels exceeding 72". Having two installers for all Optima Capz panel installations will ease the installation, minimize exposed edge damage, and help maintain proper panel alignment.

6.3. Panel Installation

Handle with clean hands and use care to avoid soiling or damage.

Step 1: Gently raise the Optima or Spectra Capz panel up until the 1/2" diameter holes fit over the 1/4" ARSTUDs

Step 2: While holding the panel up against the grid, partially thread 2 or 3 caps onto the stud to support the panel

Step 3: Insert all caps completely onto the stud finger tight

Step 4: Install remaining panels

- Align panels for uniform reveal
- Adjust minor corner elevations with threaded cap

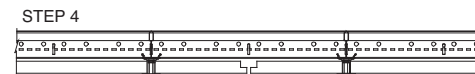
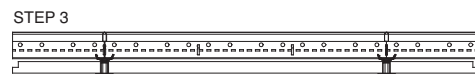
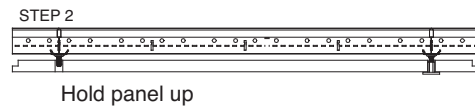
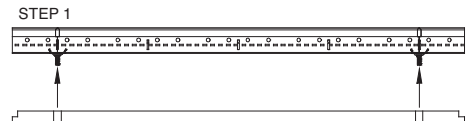

Adjust panels as required
1/4" Reveal & Elevation

6.4. Panel Removal

Step 1: Loosen 2 or 3 caps that support the panel

Step 2: Remove the remaining cap

Step 3: While supporting the panel, remove all the caps

Step 4: Gently lower the panel down off the studs

6.5. Ceiling Penetrations

Optima and Spectra Capz panel installations will generally be full-size panels and will not usually cover the entire area wall to wall. Optima and Spectra Capz panels should not be installed in areas with major plenum services or obstructions that must pass through the panels. Some plenum penetrations may require not installing an Optima or Spectra Capz panel in the desired location, leaving that space open. However the following guidelines will help when something must penetrate an Optima or Spectra Capz panel:

6.5.1. Penetration Through the Panel – When the Optima or Spectra Capz panel can be installed over the penetration – example: fire sprinkler, independent light cable, mounting bracket for AV equipment — cut a clearance hole in the panel at the correct location and install as usual.

Options for hole edge treatment are:

Option 1: Use the appropriate escutcheon or trim ring to cover the cut hole

Option 2: Cut the clearance hole 1" larger on all sides and field paint the cut edge

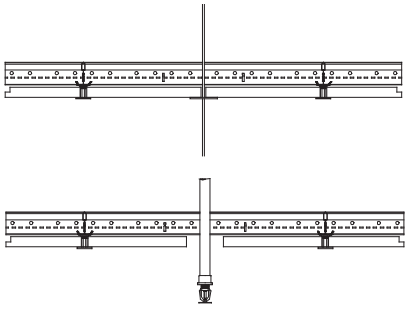

6.5.2. Notched Panel for Penetration – If the obstruction or penetration prevents the panel from fitting over it, you will need to notch the panel to fit around the penetration; e.g., structural brace, roof drain line, hangers for other services.

Step 1: Mark the penetration on the face of the Optima® or Spectra™ Capz™ panel

Step 2: Cut the notch or the corner off to provide 1" to 2" clearance around the penetration for ease of installation

Step 3: Provide additional panel support if you cut off a mounting hole. (See section 6.6.1. for details)

Step 4: Field paint the exposed edges

Step 5: Install panel

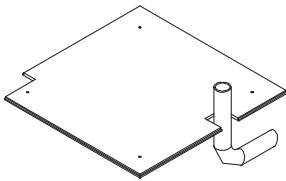

6.6. Field Cut Edges

Optima and Spectra Capz panel installation should be designed for full panels and no cut borders, however, you may need to field cut a panel in some installations.

6.6.1. Additional Panel Support is required whenever a panel mounting hole is trimmed off. This requires field drilling a new mounting hole and installing extra grid to relocate the ARSTUD.

Step 1: Field cut the panel as required to fit

Step 2: Relocate or install an extra cross tee within 6" of the trimmed edge or corner

Step 3: Install an ARSTUD on the grid to support the panel

Step 4: Measure the location of the new stud and transfer it to the trimmed panel. Drill a 1/2" hole at this location

Step 5: Field paint the cut edges and install the panel and caps as usual

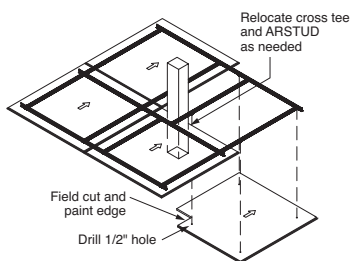

6.7. Touch-up Paint

For minor surface and edge scratches or to field paint a cut edge for Optima Capz, use Armstrong SuperCoat™ Touch-up Paint. This paint provides an excellent one coat edge treatment that will match the original panel. For minor surface and edge scuffing or scratches or to field paint a cut edge for Spectra Capz, use a flat black or satin black general purpose spray paint.

6.7.1. Optima Capz Surface Scratch or Edge Damage – Use a small brush to apply paint to the affected area. Only apply paint to the damaged area with a dabbing motion to prevent getting excess paint on the finished area. Blend or feather the paint edges to the existing panel surface.

6.7.2. Optima Capz Field Cut Edges – Use a larger 1" wide brush to apply the touch-up paint to the cut edge. Apply a liberal amount of paint to the brush and coat several inches of the cut edge. For best results, use as few strokes as possible to cover the area. Avoid getting paint on the face of the panel and wipe off any excess as soon as possible. Paint will dry in approximately 30 minutes.

6.7.3. Spectra Capz Surface Scratch, Edge Damage or Field Cut Edges – Lightly spray flat or satin black paint onto affected area. Blend or feather spray to cover damage. May need to apply two coats to field cut edge. Black latex caulk can also be used to fix edge damage.

7. LIGHTS AND FIXTURES

Lights and fixtures that mount in Optima and Spectra Capz panels may require additional suspension grid for support; e.g., speakers, can lights, life safety alarms or sensors. Additional cross tees can be installed in the grid as necessary to mount and support other fixtures. Fixtures exceeding 20 pounds may require extra grid support.

8. SLOPED INSTALLATIONS

Optima and Spectra Capz panels can be installed on a slope using the following guidelines:

- All main beams must be installed running up and down the slope
- Mains must be attached using the QSUTC rigid clip
- All panels must have one edge with studs/caps securely attached to the grid to prevent them from sliding down the slope. This can be done by installing extra cross tees between mains or by screw attaching the stud to the grid. See detail in Section 9.
- All sloped installations must be approved by local authorities at plan review

9. SEISMIC INSTALLATIONS

The following recommendations are for installations in areas of severe seismic activity and Seismic Design Category D, E and F:

- Use QSUTC for rigid grid attachment to structure
- ARSTUD must be installed at a grid intersection OR screw attached to the grid
- All single cross tee insertions must use the ARPLUG to lock the cross tee to the outside main beam

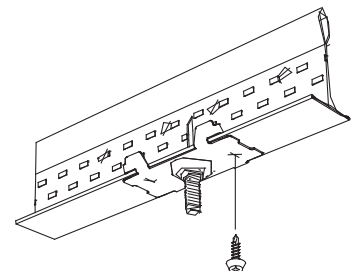

Grid Layout Example

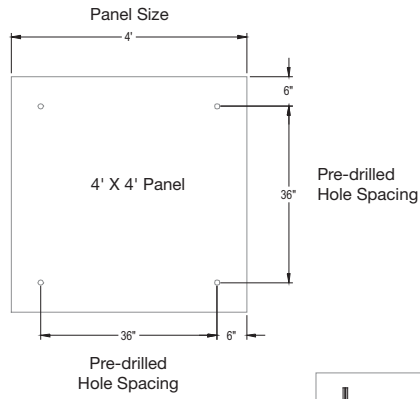

4' x 4' Panel Layout

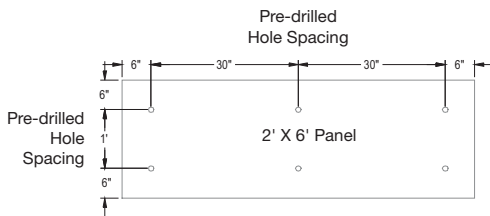
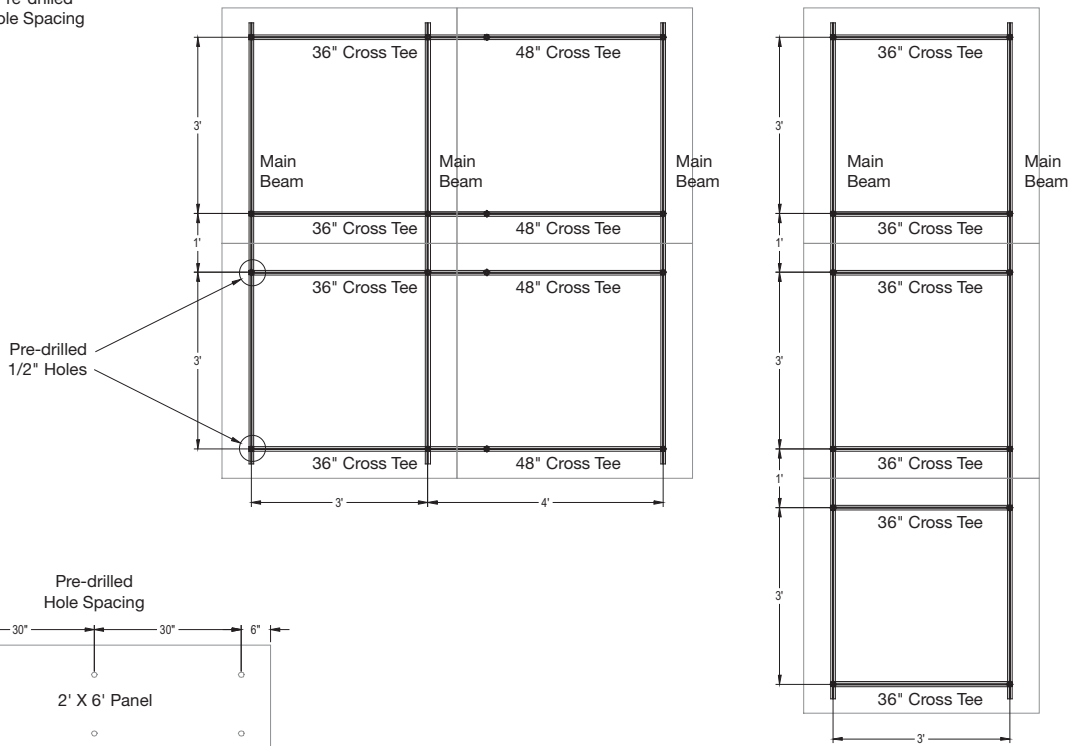

2' x 6' Panel Layout

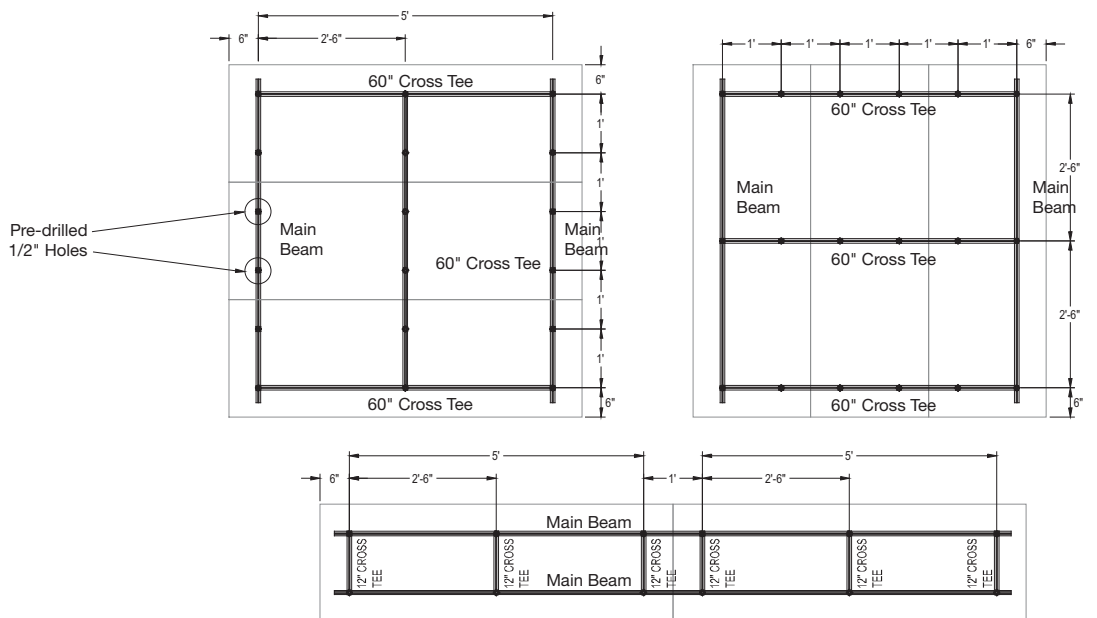

Optima[®] and Spectra[™] Capz[™] Ceiling System Assembly

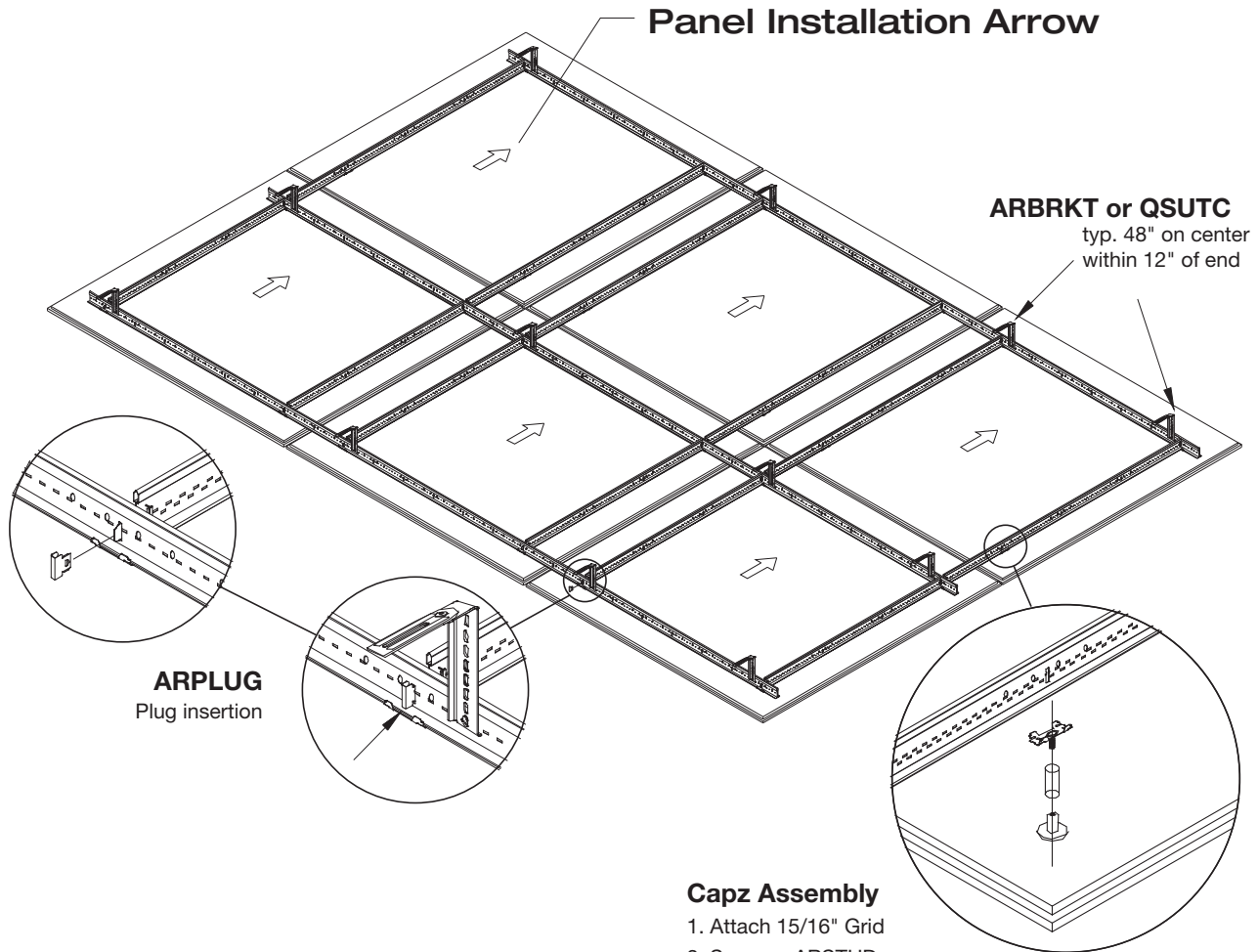

Capz Assembly

1. Attach 15/16" Grid
2. Snap on ARSTUD
3. Raise Capz Panel
4. Thread on ARCAP



Printed on recyclable paper
with vegetable-based inks.
Please Recycle. ♻️

MORE INFORMATION

For more information, or for an Armstrong representative, call 1 877 ARMSTRONG.

For complete technical information, detail drawings, CAD design assistance, installation information and many other technical services, call TechLine[™] services at 1 877 ARMSTRONG or FAX 1 800 572 TECH.

For the latest product selection and specification data, visit armstrong.com/capz

U.S. Patents Pending, including US Publication No. 2004/0182022.

All trademarks used herein are the property of AWI Licensing Company and/or its affiliates
© 2009 AWI Licensing Company • Printed in the United States of America

LA-297435-909

