



## WALL SYSTEMS

[ Between us, ideas become reality. ]®

# SOUNDSOAK® Acoustical Wall Systems Installation Instructions

## 1. INSTALLING SOUNDSOAK

Soundsoak wall panels are attached to an existing wall by means of an internal "H" spline. The base wall is typically drywall or plaster, but can be flat block, brick or concrete. For block, brick or concrete, first apply a polyethylene film to the wall as an airflow and vapor barrier. If the wall surface is irregular, apply horizontal furring strips at 12" centers.

### Tools and Additional Hardware

You'll need the following tools: utility knife and extra blades, plumb bob or level, drywall square, tape measure. (Some molding cuts may require an electric miter saw.)

Each carton of Soundsoak contains four panels and four "H" splines. In addition, you'll need #6 x 1-1/4" bugle head Hi-Low Screws (drywall and plaster installations), "J" Molding, (see "J" Molding, page 3) for the top, bottom and edges, wood nailer for the bottom, and any other finished trim desired. Chair rails and impact corners are also available from Armstrong (see "Installing Soundsoak Accessories" starting on page 3) For block, brick or concrete without furring strips, use appropriate masonry fasteners.

### ▲ CAUTION!

- Never cut one panel on top of another panel.
- Anytime the back of a panel is cut or scored for any reason, apply a heavy nonporous tape or foil to reseal the back of the panel to prevent air flow through the panel in these areas. This air flow can cause soiling of the fabric surface.
- Use clean hands when handling Soundsoak panels to prevent soiling or staining of the fabric surface. Be sure the area in which Soundsoak is to be installed is clean before installing.
- Never install Soundsoak above the ceiling line since this can create high air flow through the panel into the ceiling plenum, which can cause soiling of the fabric surface.

### ▲ WARNING! MAN-MADE VITREOUS FIBERS. POSSIBLE CANCER AND RESPIRATORY TRACT HAZARDS. CAN CAUSE TEMPORARY RESPIRATORY, SKIN AND EYE IRRITATION.

Precautionary Measures: During the installation be certain that the work site is well ventilated and avoid breathing dust. If high dust level are anticipated during installation such as with the use of power tools, use appropriate NIOSH designated dust respirator. All power cutting tools must be equipped with dust

collectors. Avoid contact with skin or eyes. Wear long-sleeve, loose fitting clothing, gloves and eye protection.

**First Aid Measures:** If contact occurs flush eyes and skin irritation with plenty of water for at least 15 minutes and remove contaminated clothing. After installing material, wash with warm water and mild soap. Wash work clothes separately from other clothing. Rinse washer thoroughly.

## 2. STEP-BY-STEP PROCEDURE

2.1 As shown in the drawings below, the "J" Molding alone may be attached to the wall or a wood base nailer or a combination of both the "J" Molding and a prefinished wood base molding.

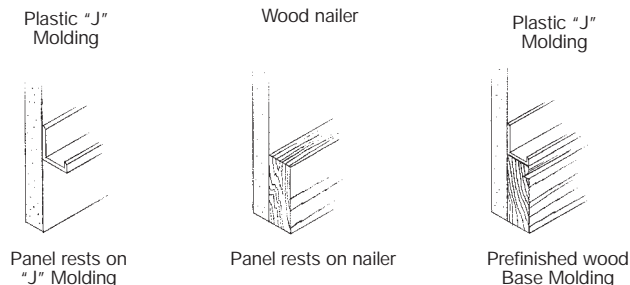

2.2 Measure the length of the wall to be covered and calculate equal size panels for each end. Along one side, drop a plumb line or use a level to draw a plumb line according to the size of the first panel. Make several measurements from the plumb line to the wall and transfer to the Soundsoak panel.

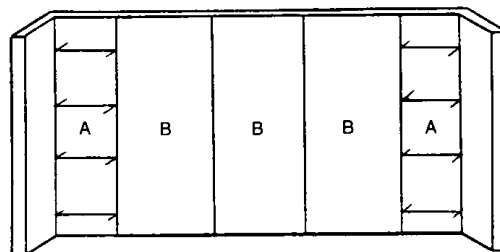

**2.3** With a sharp knife, cut the first panel. If desired, apply "J" Molding to the cut edge.

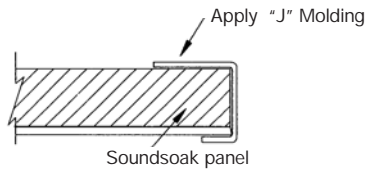

The edge can optionally be fabric-wrapped by cutting only the board and not the fabric, trimming the fabric to allow a 2-1/2" flap, and wrapping the fabric over the edge and securing it to the back with adhesive or staples.

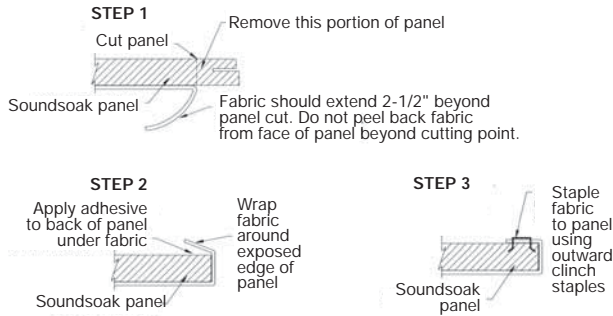

**2.4** Measure the vertical wall height to be covered and cut the panel to length. Panels can run to the ceiling line or be stopped 1" to 4" short to create a decorative reveal. Never install Soundsoak panels above the ceiling line. This can create air flow through the panel into the ceiling plenum causing soiling of the fabric surface.

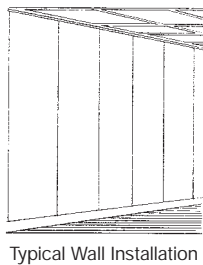

**2.5** Apply a strip or globs of panel adhesive (follow adhesive manufacturer's directions) along the back of the leading side of the first panel. Insert the "H" spline into the kerf on the trailing edge of the panel, position on the wall, and attach the spline to the wall using #6 x 1-1/4" bugle head Hi-Low Screws (5 to 6 per spline).

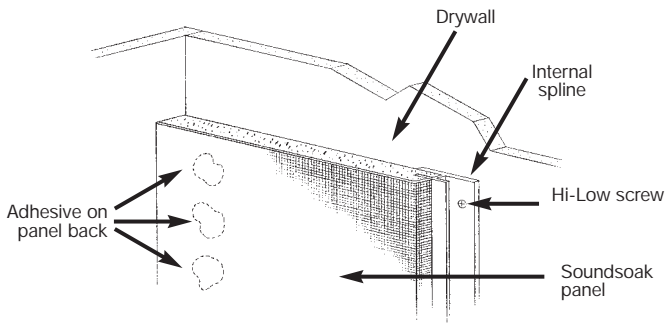

**2.6** Cut the next panel to length and insert the lead edge into the previously attached "H" spline, insert another spline into the trailing edge, and attach to the wall as before. Proceed progressively along the wall as described.

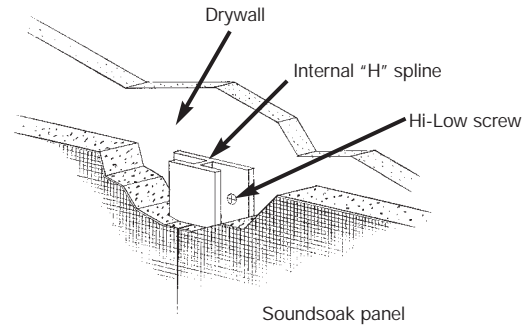

**2.7** When installing Soundsoak around door or window frames, there are two options for handling edge treatment. Use either a "J" Molding or a fabric-wrapped edge as previously described in Step 3. Around receptacles, follow standard electrical codes. Anytime the back of a panel is cut or scored, apply a heavy nonporous tape or foil to reseal the back to prevent air flow through the panel which can cause soiling of the fabric surface.

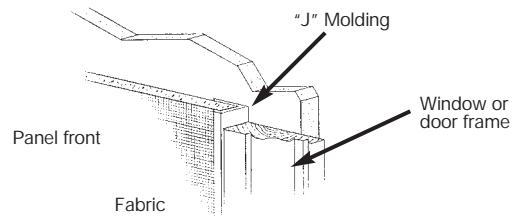

**OPTION 1.** Butt cut the board, and use a plastic "J" Molding as a finishing piece.

**OPTION 2.** Cut out the mineral fiber or fiberglass substrate only. Leave 2-1/2" of fabric. Wrap fabric to back of board (See step 3).

**2.8** Outside corners can be handled using a corner molding for protection or two fabric edge-wrapped panels as previously described. A continuous-wrapped corner can be created by cutting a square block out of the back of the board without cutting the fabric, then folding the panel as shown. See Impact Corners on page 3.

**CONTINUOUS-WRAPPED CORNER**

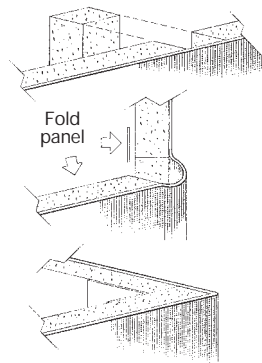

**TWO FABRIC-WRAPPED BUTTED PANELS**

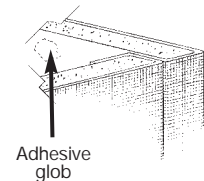

**2.9** Measure for the last panel and cut. Apply a "J" Molding or fabric-wrap the panel as described earlier. Use a strip or globs of panel adhesive to secure the trailing side of the last panel.

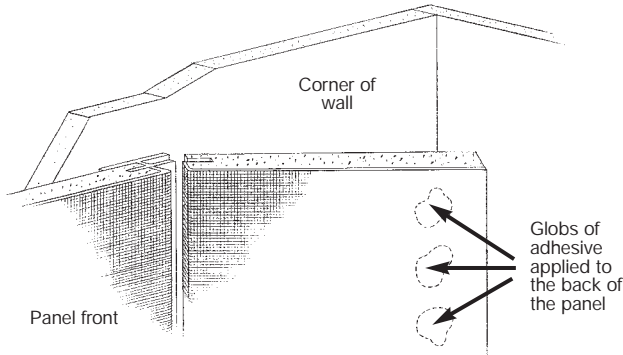

**2.10** When panels are stacked vertically on a wall, use two "J" Moldings, an "H" Molding, or a wood nailer plus finish trim inserted between the upper and lower panels.

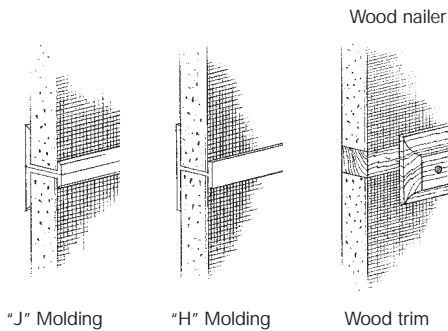

**2.11** Apply "J" Molding to the top of the panels. Apply any other finish trim desired such as cove molding or wood molding.

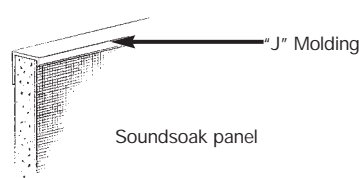

### 3. INSTALLING SOUNDSOAK ACCESSORIES

#### 3.1 "J" Molding

Use Soundsoak "J" Molding to cap the edges of Soundsoak panels at top and bottom. "J" Molding also provides a clean look where Soundsoak is cut around doors and window casings or at the end of a run of panels.

Two widths are supplied: nominal 3/4" for mineral fiber, and nominal 1" for fiberglass (Soundsoak 85) panels. Both are offered with a 3/8" lip for easy installation, and come in black, frost grey, sand, grid white and light tone. 3/4" "J" Molding is also offered with a fine 1/4" lip (in black only).

**3.1.1** Cut moldings to length using a fine-tooth electric or manual saw. Moldings are offered in 10' sections.

**3.1.2** Miter outside corners; inside corners may be butt cut or mitered.

**3.1.3** Screw "J" Molding to the wall studs. Insert panel edge into the "J" Molding concealed mounting flange.

#### 3.2 Impact Corners

The Impact Corner is a two-piece trim designed for use on outside corners of Soundsoak installations.

**3.2.1** The black retainer should be cut to length and mechanically attached to the wall surface. Ensure that the retainer is straight and plumb on both sides of the corner.

**3.2.2** The panels should be cut snug to the stops on the retainer to ensure that they do not move after installation.

**3.2.3** The fabric-wrapped corner dart must be cut to length carefully to avoid fraying. Trim any loose threads before installation.

**3.2.4** Align the corner dart with the recess on the retainer and drive it in until it is securely seated against the face of the panel.

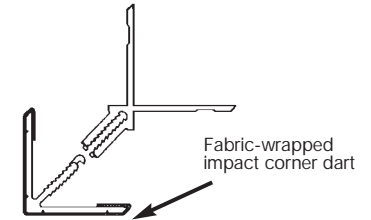
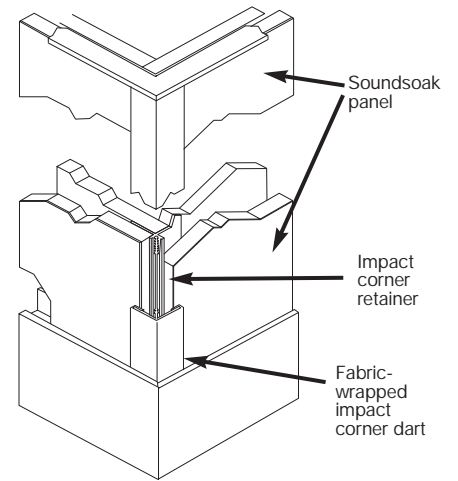
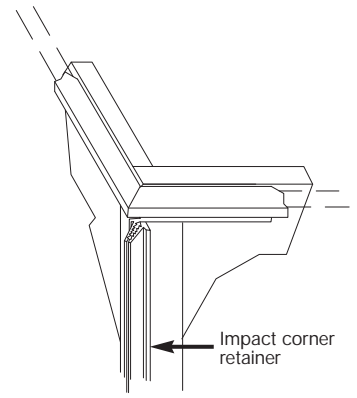

#### 3.3 Chair Rails

Chair rail accessories designed for use with Soundsoak panels are available in a variety of finishes, including "unfinished" components for field painting. It is typically a two-piece installation with a Mounting Rail first and either a Rail Insert or Easel Ledge attached to that rail.

##### 3.3.1 Mounting Rail with Rail Insert

Mark a level line on the wall at the desired height of the chair rail.

If you are going to install fiberglass Soundsoak 85 above or below the chair rail, you must first place the Rail Spacer behind the Mounting Rail.

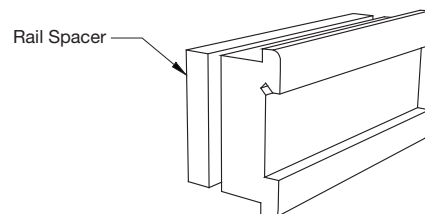

Predrill and countersink holes for flat head screws in the channel of the Mounting Rail.

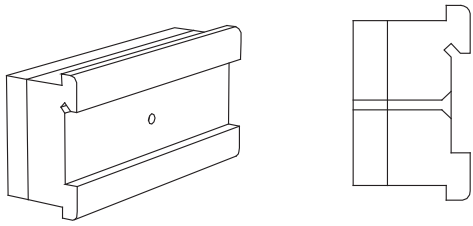

Align rail with the level line and fasten the rail to each wall stud. Use flat head screws appropriate for the wall construction.

Install your choice of Rail Insert in the channel using carpenter's glue and brads. Five of the six finishes of Rail Inserts can be visually applied in two ways - with either the flat side or reveal edge showing.

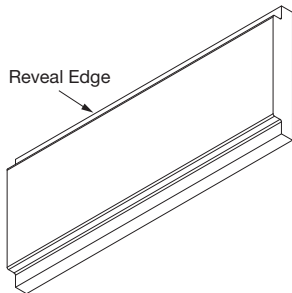

NOTE: The Rail Insert with the aluminum face can only be applied visually as a flat side and can be secured to the rail with double-faced tape (by others). The aluminum Rail Insert has a protective film on the face that should be removed before securing to the rail.

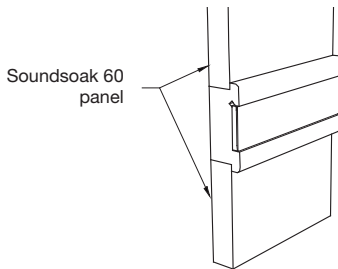

Mineral fiber Soundsoak 60 wall panels fit above and/or below the chair rail and rest in the channel on the top and/or bottom side of the Mounting Rail.

If wall panels are to be used in a partial installation with wall panels below the chair rail, but not above the chair rail, install a Rail Cap above the Mounting Rail using carpenter's glue and brads. Rail Cap (item 5864) is used with mineral fiber Soundsoak 60 panels, and the Extended Rail Cap (item 5865) is used with fiberglass Soundsoak 85 panels, along with the Rail Spacer.

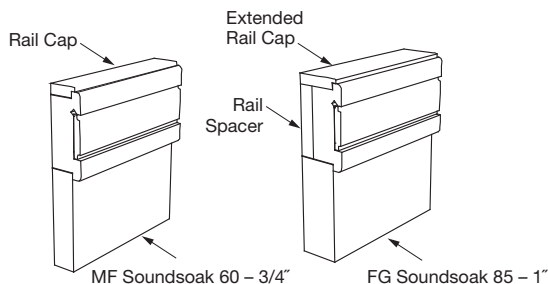

### 3.3.2 Mounting Rail with Easel Ledge

Mark a level line on the wall at the desired height of the chair rail.

If you are going to install fiberglass Soundsoak 85 above or below the chair rail, you must first place the Rail Spacer behind the Mounting Rail.

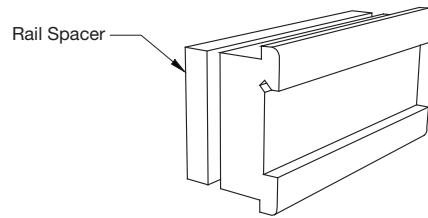

Predrill and countersink holes for the flat head screws in the insert channel of the Mounting Rail.

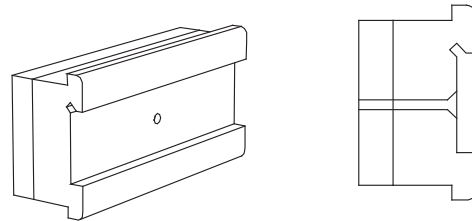

Align rail with the level line and fasten the rail to each wall stud. Use flat head screws appropriate for the wall construction.

If wall panels are to be used in a partial installation with wall panels below the chair rail, but not above the chair rail, install a Rail Cap above the Mounting Rail using carpenter's glue and brads. Rail Cap (item 5864) is used with mineral fiber Soundsoak 60 panels, and the Extended Rail Cap (item 5865) is used with fiberglass Soundsoak 85 panels, along with the Rail Spacer.

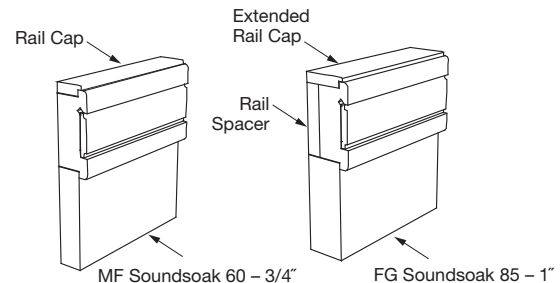

Insert the Easel Ledge into the grooved accent channel of the Mounting Rail and secure it in place with screws through the predrilled and countersunk holes as shown.

NOTE: The Easel Ledge installation into the Mounting Rail is the same whether or not partial wall installation with Rail Caps is used.

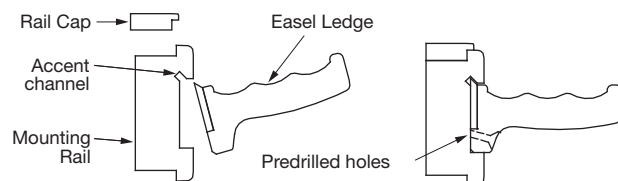

#### **4. MAINTAINING SOUNDSOAK**

**4.1** Routine maintenance of Soundsoak wall panels should include frequent vacuuming to minimize dirt accumulation.

**4.2** A dry or wet carpet shampoo can be used on Soundsoak fabric. A dry shampoo from a spray can is applied to the fabric as a foam and worked into the fabric with a damp sponge. The residue is then vacuumed to remove the foam and dirt. A wet shampoo is a sprayed cleaning agent which foams after it is applied. Work in with a damp sponge, and vacuum to remove residue.

**4.3** To remove stains which do not respond to removal by wet or dry shampoo (oil- or grease-type spots), use a solvent-type cleaner like perchloroethylene. Be sure to have proper ventilation when using these materials. Apply the removal agent to a clean cloth or sponge, not directly to the fabric. Blot the stain, using a twisting and lifting motion toward the center of the spot. Repeat as necessary.

**4.4** Badly soiled Soundsoak panels can be cleaned using a steam cleaning or hot water extraction process. Small residential steam cleaners can be used much in the same manner as cleaning upholstery. However, be very careful not to overwet the panel surface since this can cause fabric delamination. Commercial steam cleaners should use their upholstery tool since this applies only a fine mist and will not overwet the panel. The commercial vacuum should be reduced to about 30 psi to prevent damage to the panel.

**4.5** Vinyl-faced Soundsoak can be cleaned with soapy water, using a sponge or cloth.

## MORE INFORMATION

For more information, or for an Armstrong representative, call 1 877 ARMSTRONG.

For complete technical information, detail drawings, CAD design assistance, installation information and many other technical services, call TechLine<sup>SM</sup> services at 1 877 ARMSTRONG or FAX 1 800 572 TECH.

For the latest product selection and specification data, visit [armstrong.com/soundsoak](http://armstrong.com/soundsoak).