

METALWORKS™ Canopies

Installation Instructions

1. GENERAL

1.1 Product Description

MetalWorks Canopies are pre-formed acoustical canopies available in Hill, Valley or Flat configurations and are suspended with cables.

1.2 Materials and Finishes

MetalWorks panels consist of a pre-formed galvanized steel structure encasing a fiberglass sound absorbing pad. Canopies are available unperforated, microperforated or extra microperforated, and are finished with post fabrication powder coat available in White (WH), Silver Grey (SG) and Gun Metal Grey (MY). **NOTE:** This white color is slightly different than Armstrong global white.

1.3 Components

1.3.1 Canopies

MetalWorks Canopies are 46-1/2" wide by 74-1/2" long by 1-1/2" thick. Curved canopies have a fixed arc radius of 9'.

1.4 Suspension System

MetalWorks Canopies are suspended with cables. Complete suspension cable kits are supplied with each canopy. They consist of four 6'-6" cables per canopy and hardware to attach the cables to the canopy and structure with an adjustable gripper to easily set the proper elevation.

1.5 Storage and Handling

MetalWorks Canopies shall be stored in a dry interior location and shall remain in cartons prior to installation to avoid damage. The cartons shall be stored in a horizontal position. Proper care should be taken when handling to avoid damage or soiling.

NOTE: MetalWorks Canopies weigh in excess of 60 pounds. Exercise care in moving and opening cartons to prevent injury or damage to the product.

1.6 Jobsite Conditions

Building areas to receive canopies shall be free of construction dust and debris. Products can be installed in conditions between 32°F (0°C) and 120°F (49°C) and in

spaces before the building is enclosed, where HVAC systems are cycled or not operating. Cannot be used in exterior applications, where standing water is present or where moisture will come in direct contact with the ceiling. Cannot be installed over areas such as swimming pools, which provide direct contact with corrosive agents, such as chlorine.

1.7 Design Considerations

MetalWorks Canopies are not approved for exterior application. The MetalWorks Canopies cable hanging system must not hang from any commercial ceiling suspension system. The canopy must not be used to support any other material. Escutcheon kits are available as a separate accessory (BP7006) for use when hanging a canopy below an existing ceiling. Two of these kits are needed per MetalWorks Canopy.

1.8 Fire Performance

MetalWorks Canopies, as with other architectural features located in the ceiling plane, may obstruct or skew the existing or planned fire sprinkler water distribution pattern, or possibly delay the activation of the fire sprinkler or fire detection system. Designers and installers are advised to consult a fire protection engineer, NFPA 13, and their local codes for guidance on the proper installation techniques where fire detection or suppression systems are present.

Contact Techline at 1-877-276-7876, option 1, then 2, then 3 for specific US and Canadian fire performance data.

2. INSTALLATION

See page 3 for drawings.

2.1 General

After opening the product carton, and before installation, be sure to locate, remove and set aside the hardware kit before proceeding.

MetalWorks Canopies require two people to handle each panel safely, minimize damage and provide panel support during installation. **DO NOT REMOVE THE CANOPIES FROM THE CARTON** until the suspension cables are attached to the building structure and ready to receive the panel.

MetalWorks panels cannot be cut, drilled or altered in any way. The canopy must not be used to support any other material. The cable suspension system must be fastened to the structure and cannot be hung from any commercial ceiling system.

MetalWorks panels are not approved for exterior application.

2.2 Suspension Cables

Canopies must be installed with four suspension cables.

2.2.1 Cable Attachment to Structure

Layout the attachment points for the structure anchors.

The pattern for the placement of these anchors when the canopy is installed level is 23-5/8" x 37-3/8".

The International Building Code requires the attachment of free floating architectural components to be sized for three times the design load. Flat canopies weigh 58 pounds, curved canopies weigh 62.4 pounds. Select hardware that will satisfy these requirements and is appropriate for the structure to which they will be attached.

The structure anchor is fabricated with 1/4"-20 NC internal threads. The anchor may be turned onto a matching stud, or fastened with a screw through the hole in the anchor and into the supporting structure.

Additional structural support may be required if cable anchor points are obstructed by HVAC, piping or other components in the plenum.

Cables must have 6" clearance from all plenum obstructions.

2.2.2 Installing the Canopy Below an Existing Ceiling

NOTE: Canopy suspension cables should not impose any lateral force on an existing ceiling.

NOTE: The structure gripper anchor must be mounted to a support at or above the existing ceiling.

Use 1/4" - 20 threaded rod attached to structure to secure the structure gripper anchor at the correct height.*

Install diagonal bracing to structure to provide lateral support.

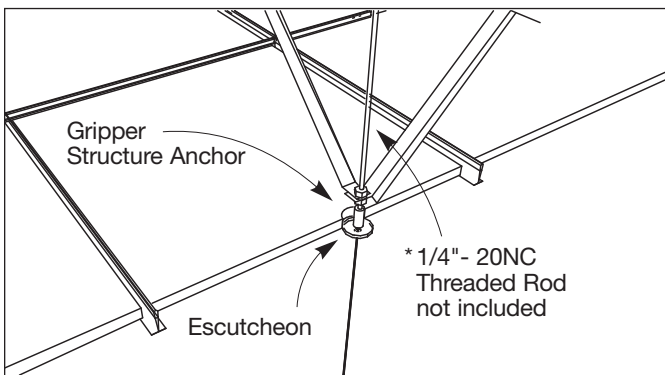

Use the optional escutcheon kit accessory to conceal the structure gripper anchor when installed above the ceiling level.

Escutcheon Kit (BP7006)
 (2) Collars with set screws
 (2) Escutcheons (2")

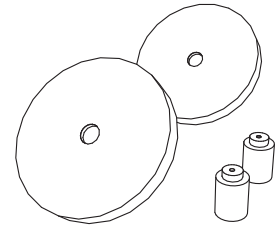

NOTE: Two kits are required for each canopy.

2.2.3 Attach Cable to Structure Anchor

Install one of the large painted washers over the free end of each cable. Insert the cable from the unfinished side of the washer.

Push the plain end of the cables through the narrow barrel on the gripper adjuster. Feed the end of the cable through the hole located in the side of the gripper structure anchor and thread the adjuster into the structure anchor.

Repeat for the remaining three cables.

2.2.4 Suspend the Canopy (two people required)

Make sure your hands are clean or wear white cotton gloves.

Attach each cable by feeding the lugged end into the notches provided on the top side of the canopy.

Ensure that the lug is properly seated. The narrow end of the lug should extend through the end of the slot in the canopy and the cable should extend straight up out of the back of the panel.

Position the washers installed in step 2.2.3 over the cable lugs to conceal the attachment slots on the back side of the panel.

IMPORTANT: In areas subject to moderate to severe seismic activity secure each washer to the canopy by inserting a self drilling screw through the washer and into the back of the panel.

IMPORTANT: Canopies must be installed so the lowest point is a minimum of 7'-6" above the finished floor.

Then, raise the panel and gently pull the cable(s) to take up the slack. Do not pull the cables to raise the canopy under full panel weight. Cable damage will occur. Continue to raise the canopy until at the required height. Canopies can be installed up to a 45-degree angle in either direction.

To lower the canopy, take the weight off the cable(s), depress the plunger located at center of cable adjuster and lower the canopy. Release the plunger to lock the cable into the adjuster.

2.2.5 Clean and Adjust

After the panel height is correct, cut off excess cable leaving about 1" remaining out the cable adjuster.

Use a clean, soft white cloth and mild detergent and water to wipe off any dirt or fingerprints. Regular light dusting of the back side of the canopy is recommended.

2.2.6 Seismic Restraint* and Installation

The 2003 International Building Code allows architectural components to swing freely as long as they will not be damaged or cause damage. Canopies suspended will swing no more than 18" in any direction for each panel (36" for adjacent canopies). The current 2006 edition of the code requires only that canopies not cause damage to essential building components. 18" clearance must be maintained between a canopy and any essential building element. Restraint of canopies is not recommended.*

*Pendulum reaction information is based on full scale testing and computer modeling conducted at the Structural Engineering Earthquake Simulation Lab located at the State University of New York at Buffalo.

Elevation Views*

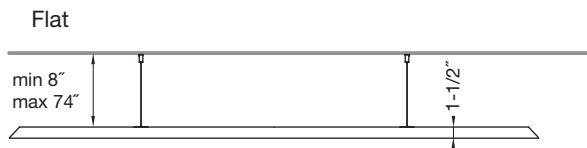
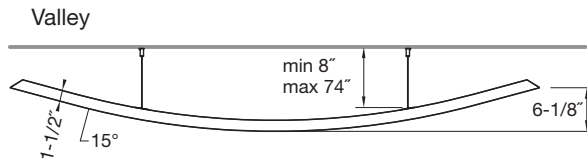
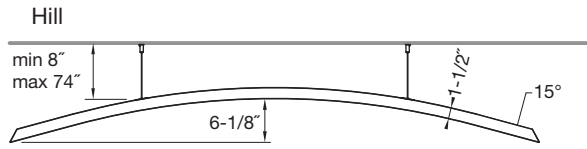

Plan View (for Flat, Hill and Valley panels)

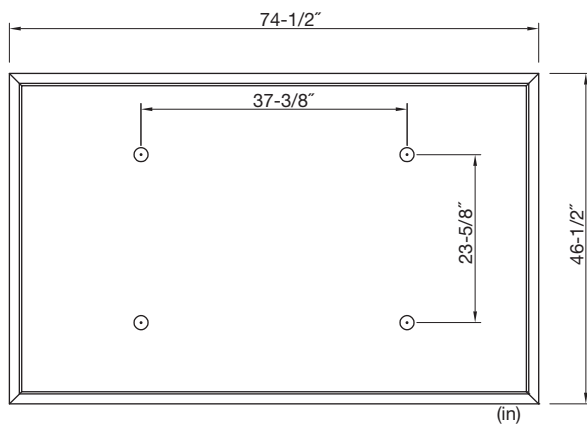

* All measurements are nominal.

Suspension Hardware

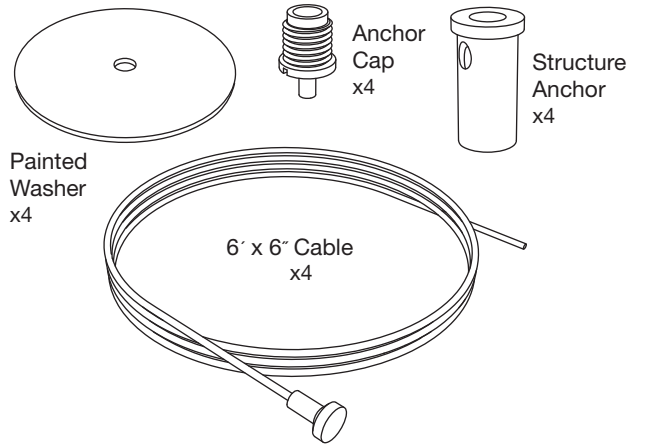

Hardware Installation

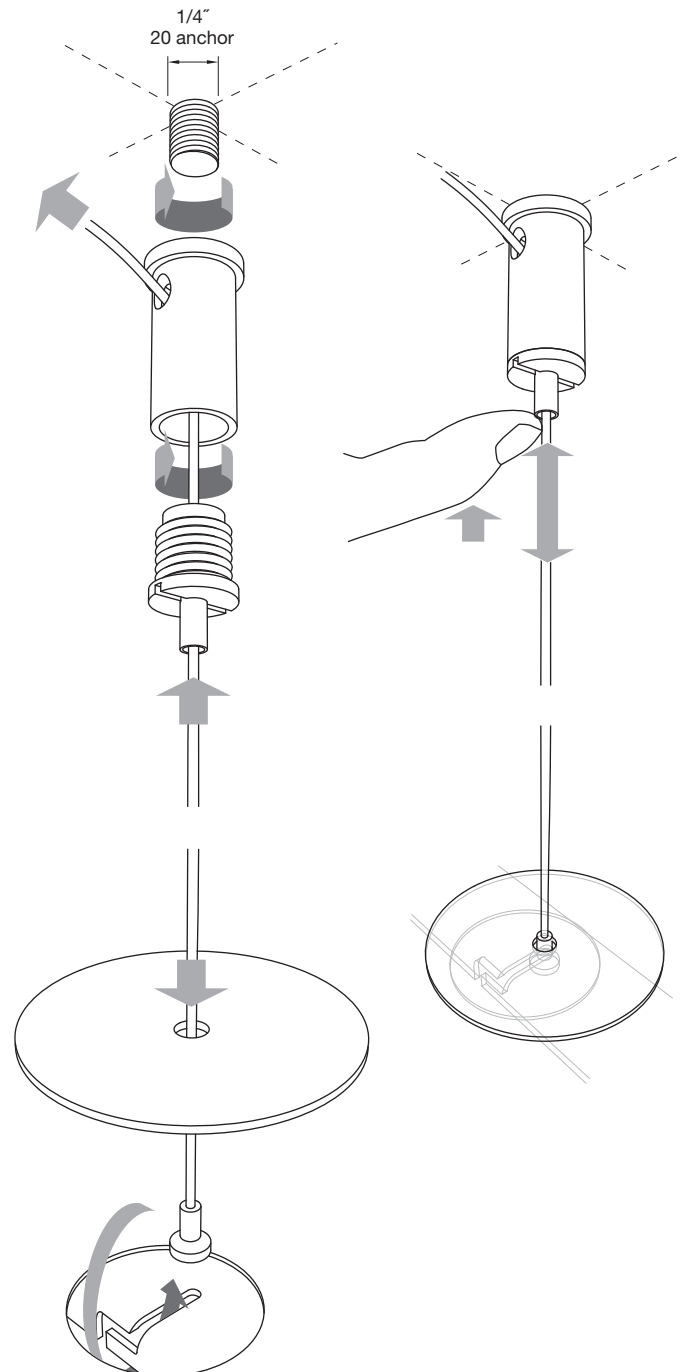



Printed on recyclable paper
with vegetable-based inks.
Please Recycle. 

MORE INFORMATION

For more information, or for an Armstrong representative, call 1 877 ARMSTRONG.

For complete technical information, installation information and many other technical services, call Architectural Specialties at 1 877 ARMSTRONG, and select options 1-1-4.

For the latest product selection and specification data, visit armstrong.com/metalworks.

