



## CEILING SYSTEMS

[ Between us, ideas become reality.™ ]

# METALWORKS RH-215 HOOK-ON PANELS General Installation Instructions

## 1. GENERAL

### 1.1. Product Description

MetalWorks RH-215 Hook-on Panel system is a downwardly accessible, metal ceiling available in a range of sizes. It is designed to install on an Armstrong Hook-on H-Bar suspension system. All full panels can be removed and re-installed with minimal access to the plenum.

Two sides (typically the short sides) support the installed panels. Each corner will have a hook detail that allows the panel to engage on the H-Bar suspension element. Both ends are the same, insert the hooks of one end onto the H-bar as far as possible. Raise the opposite end up and slide the panel back to engage the corner hooks, the opposite end hooks will now engage onto the H-bar securing all four corners of the RH-215 panel in place. The other sides have vertical returns; the panels are self-supporting without sag.

### Gaskets

A foam "Gasket" is optional on the RH-215 panel. The gasket (standard width 3 mm - 1/8") allows panels to be installed and removed easily, provides a tolerance factor, and creates a uniform reveal joint. Gaskets will be indicated on the shop drawings. Field applied gasket should be installed a minimum of 1/8" above the panel face

### Perforations

Panels may be perforated or non-perforated. A factory installed acoustical fleece is typically provided for sound absorption. Add the optional field installed acoustical infill for increased sound absorption if required.

### Surface Finish

MetalWorks panels are powder coated after forming (post coat). The surface of these panels is impact resistant, cleanable and non-directional.

### 1.2. Storage and Handling

The ceiling panels shall be stored in a dry interior location and shall remain in cartons prior to installation to avoid damage. The cartons shall be stored in accordance with the instructions on the carton. Proper care should be taken when handling to avoid damage or soiling.

### 1.3. Site Conditions

Building areas to receive ceilings shall be free of construction dust and debris. Panels should only be installed in closed and acclimatized buildings. The systems cannot be used in

exterior applications, where standing water is present or where moisture will come in direct contact with the ceiling.

### 1.4. Plenum

Since panels are installed from below, MetalWorks RH-215 Hook-on panels require minimal clearance above the suspension system.

**NOTE:** light fixtures and air handling systems require more space and will usually determine the minimum plenum height for the installation.

### 1.5. Ceiling Panel Layout.

The ceiling panel layout should have perimeter panels equal on opposite sides. The cut perimeter panels should be more than 50% of their original length and width. This will create the best visual.

## 2. SUSPENSION SYSTEM

### 2.1. General

The suspension system shall be Armstrong "U" profile (BPM300.100) and H-Bar (BPM330.016) suspension elements. The suspension system shall be properly installed and leveled using not less than 12-gauge galvanized steel wire. Suspension system installation shall conform to ASTM C-636 requirements.

### 2.2. Suspension Grid – U-profile

MetalWorks Hook-on panels may be installed in a variety of modules. The U profiles shall be spaced 48" O.C. with a maximum distance of 18" to a perimeter wall or outside edge of a floating module. The top of the U-profile is 3-5/8" above the finished ceiling height. The H-Bars shall intersect the U profile at 90° at every module (the module is dictated by the length of the panel – consult the shop drawings). The H-Bar is connected to the U profile with a H-bar hanger (BPM311.0156). (See Drawing #1 & #2)

### 2.3. Suspension Grid – H-bar

2.3. The H-bar grid element is non-directional. Position H-bar hangers on the U-profile where the H-bar is to be installed. Raise the H-bar up against the bottom of the U-profile and rotate the H-bar hanger to secure the components together. Bend both tabs on the H-bar hanger down to prevent the hanger from disengaging. Use the Plug-in clip (BPM300.120) to secure the H-bar hanger to the U-profile at the desire module. Repeat this process until all H-bar hangers are secured in place. Use the H-bar splice (BPM311.017) to

connect adjoining sections of H-bar.  
(See Drawing #2)

#### 2.4. Suspension Grid Alignment

It's recommended the U-profiles and H-bars be fastened to two adjacent walls using the wall anchor (BPM300.140). Wall anchors are slotted to allow alignment of the grid system for proper squareness. The H-Bars must be leveled to within 1/4" in 10' and must be square to the U profile within 1/16" in 2'. Drop heights from U profile to H-Bar shall be accurate plus or minus 1/16".  
(See Drawing # 4)

### 3. Panel Installation & Removal

#### 3.1. General

MetalWorks Hook-on ceiling panels are easily installed and removed from below the suspension system allowing easy downward access to the plenum.

#### Panel Orientation

Before beginning panel installation refer to the shop drawing for correct panel size and orientation

#### 3.2. Installing Panels

Note that panels are the same detail. Either end can be installed or removed first. Install all full sized panels as shown on the shop drawings.  
Optional foam gasket must be applied before panel installation.

Step 1: Insert the corner hooks of one end onto the H-bar as far as possible.

Step 2: Raise the opposite end of the panel up until it touches the bottom of the next H-bar.

Step 3: Gently slide the panel back until the corner hooks engage over the H-bar. The opposite corner hooks will engage the H-bar as the panel is lowered into place.

(See Drawing # 6)

Repeat process until first row of panels is in place. Subsequent rows of panels are installed similarly..

It is not necessary to use any specific sequence, as all panels are fully accessible with or without the other panels installed.

#### 3.3. Panel Alignment

The use of a laser or string line is recommended to establish straight panel alignment. Panels may be slid along the H-bar to adjust alignment as necessary. Mechanically secure a row of panels to the H-bar to maintain correct alignment and to prevent subsequent misalignment during routine access and replacement

#### 3.4. Panel Penetrations

Holes cut for sprinkler heads, light fixtures, speakers and other services that penetrate the ceiling panel may be field or factory cut. See separate MetalWorks installation instructions for details.

#### 3.5. Panel Removal

Removal is simply the reverse of installation.

Step 1: Push up on the RH-215 panel to disengage the corner hooks.

Step 2: Gently slide the panel in either direction. (typically the short sides)

Step 3: Lower the opposite end until it clears the H-bar

Step 4: Gently slide the panel towards the lowered end until the opposite end comes off the H-bar and lower the panel

(See Drawing # 6)

### 4. PERIMETER DETAILS

Either the panels will all be full size or the cut edges will rest on and be concealed by some form of wall trim.

#### 4.1 Cutting Metal Panels

##### ▲ CAUTION

Cut edges of metal parts can be extremely sharp! Handle metal carefully to avoid injury. Always wear safety glasses and gloves when working with metal.

See **MetalWorks Cutting Instructions** (LA 295518) for detailed information about cutting Armstrong metal ceilings. This document discusses the advantages and disadvantages of several types of equipment and how they are used when cutting our products

#### 4.1.1 Cutting Perimeter Panels

Perimeter panels will have to be cut and fit as needed. Carefully measure the perimeter opening and transfer this dimension to the panel. Cut the metal ceiling panel to fit the specified wall trim option. Install the panel and secure the cut edge on the perimeter molding as indicated on the shop drawing.  
(See Drawings # 4)

#### 4.1.2 Aluminum F-Molding Wall Trim

Use F-molding Wall Angle (BPM330.003) or F-molding Shadow Wall Angle (BPM330.011) around the perimeter. Molding must be securely fastened to the wall every 16" to 24". The cut edge of the MetalWorks panel will rest on the horizontal flange. Insert the pressure spring (BPM311.081) into the channel to keep the cut edge tight on the wall molding.  
Use the Shadow F-molding to create a reveal between the wall and molding.  
(See Drawing # 5)  
Insert the corner element (BPM331.082) into the channel for proper F-molding alignment for both inside and outside mitered corners.  
(See Drawing # 4)

#### 4.1.3 Channel Molding Wall Trim

Use Armstrong Channel Molding #7835 around the perimeter. Molding must be securely fastened to the wall every 16" to 24". The cut edge of the MetalWorks panel will rest on the bottom horizontal flange. Insert a #7835SC spreader channel to keep the cut edge tight on the wall molding.  
(See Drawing # 5)

# RH215 SUSPENSION INSTALLATION

U-PROFILES ARE INSTALLED 48" ON CENTER WITH A MAXIMUM DISTANCE OF 18" TO THE PERIMETER WALLS.  
U-PROFILES ARE SUSPENDED WITH 12 GA GALVANIZED WIRE, WIRES MUST BE WITHIN 18" OF THE PERIMETER WALL, THEN 48" ON CENTER.  
HANGER WIRE MUST BE WRAPPED TIGHTLY WITH 3 FULL WRAPS WITHIN 3" OF THE U-PROFILE.  
LEVEL U-PROFILE TO WITHIN 1/4" IN 10 FEET (ASTM C-636). U-PROFILE WILL BE 3-5/8" ABOVE THE FINISHED CEILING HEIGHT.

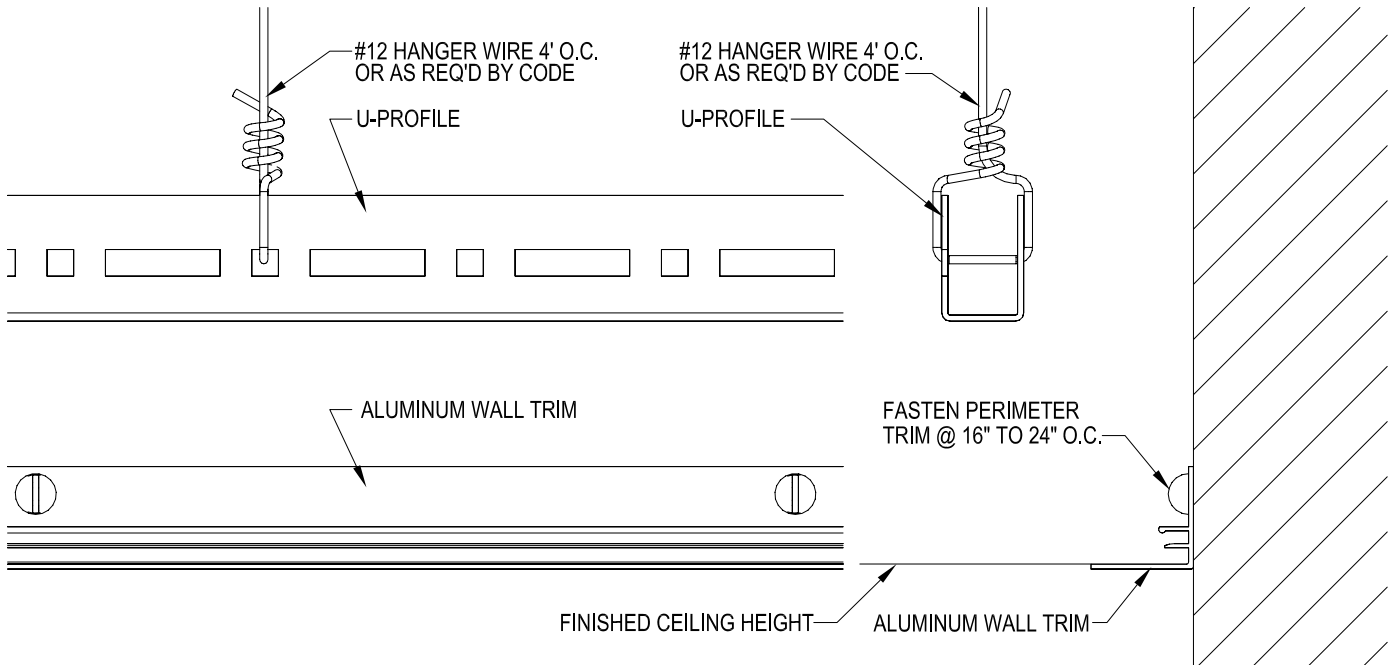
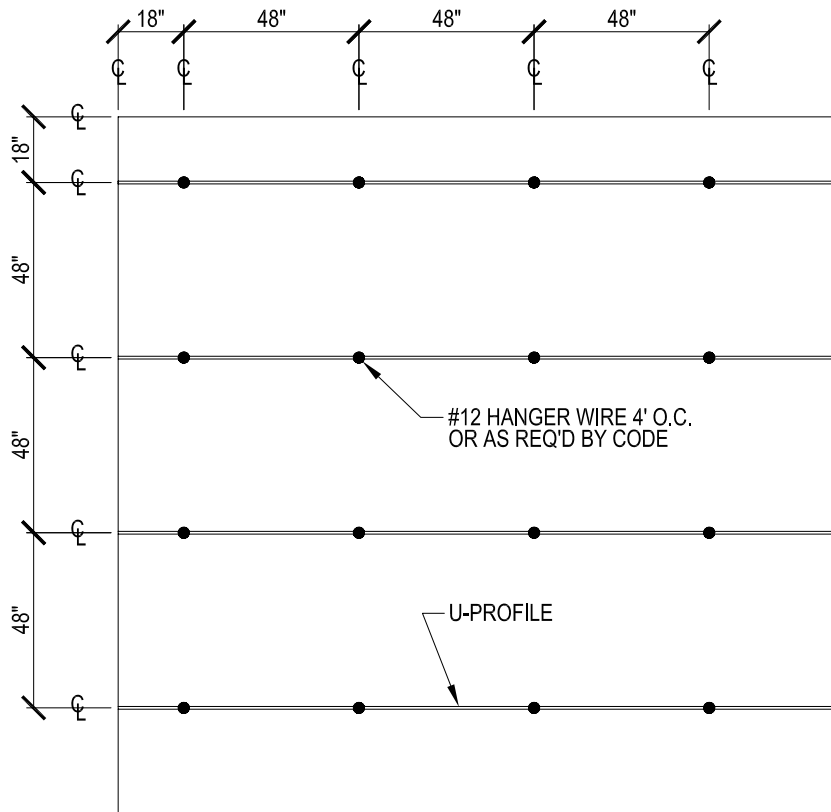

DRAWING 1

## RH215 H-PROFILE INSTALLATION

POSITION H-BAR HANGERS ON THE U-PROFILE. RAISE THE H-BAR UP AGAINST THE BOTTOM OF THE U-PROFILE AND ROTATE THE H-BAR HANGER TO SECURE THE COMPONENTS TOGETHER. BEND BOTH TABS ON THE H-BAR HANGER DOWN AND USE THE PLUG-IN CLIP TO SECURE THE H-BAR HANGER TO THE U-PROFILE AT THE DESIRED MODULE. USE THE H-BAR SPLICE TO CONNECT ADJOINING SECTIONS OF H-BAR. USE A WALL ANCHOR TO ATTACH THE H-BAR TO THE PERIMETER WALL.

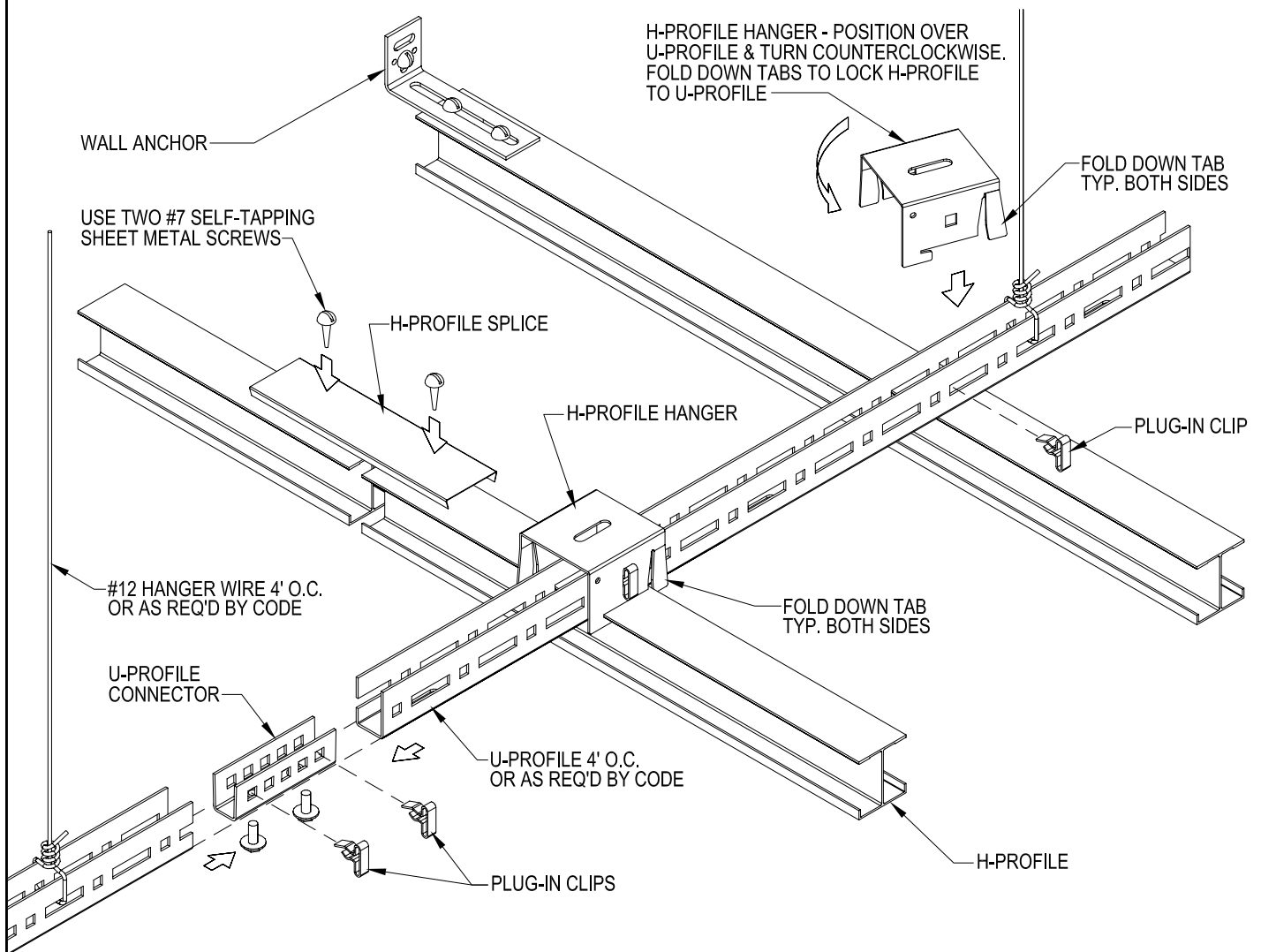

DRAWING 2

## RH-215 PANEL INSTALLATION

RH-215 PANEL CORNERS HAVE A HOOK DETAIL THAT ALLOWS THE PANEL TO ENGAGE ON THE H-BAR. BOTH ENDS ARE THE SAME SO EITHER END CAN BE INSTALLED OR REMOVED FIRST. REFER TO THE SHOP DRAWING FOR CORRECT PANEL SIZE AND ORIENTATION. THE USE OF A LASER OR STRING LINE IS RECOMMENDED TO ESTABLISH STRAIGHT PANEL ALIGNMENT. PANELS MAY BE SLID ALONG THE H-BAR TO ADJUST ALIGNMENT AS NECESSARY.

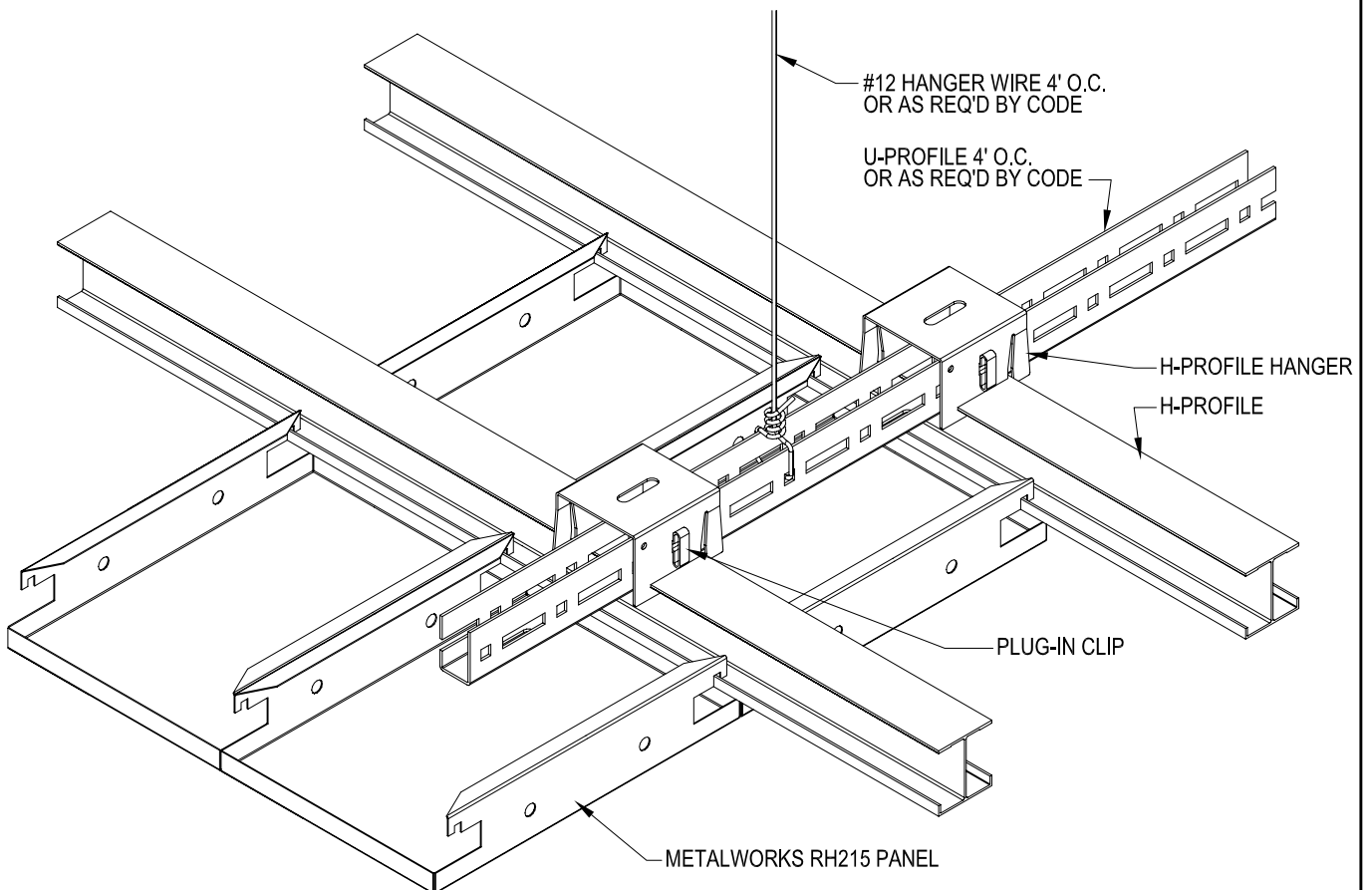
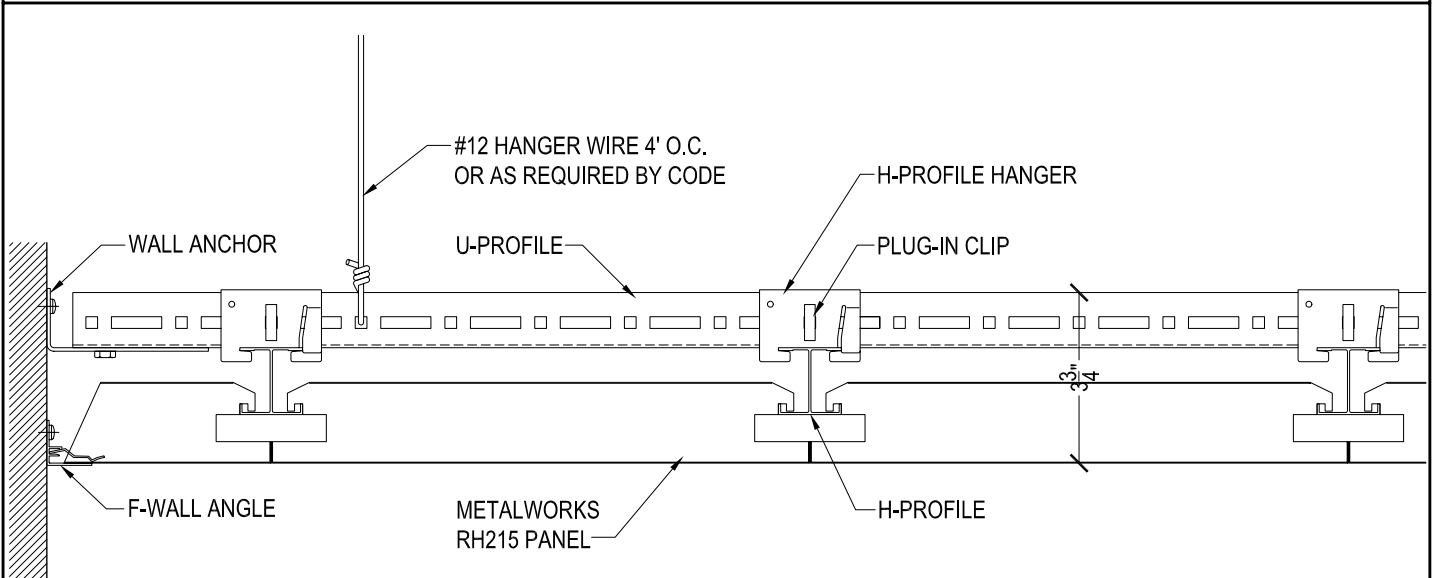

### RH-215 PERIMETER PANEL INSTALLATION

IT IS RECOMMENDED THE U-PROFILES AND H-BARS BE FASTENED TO TWO ADJACENT WALLS USING THE WALL ANCHOR. WALL ANCHORS ARE SLOTTED TO ALLOW ALIGNMENT OF THE GRID SYSTEM FOR PROPER SQUARENESS. THE H-BARS MUST BE LEVELED TO WITHIN 1/4" IN 10' AND MUST BE SQUARED. CUT THE PERIMETER METAL CEILING PANEL TO FIT THE SPECIFIED WALL TRIM OPTION. INSERT THE CORNER ELEMENT INTO THE CHANNEL FOR PROPER MOLDING ALIGNMENT FOR BOTH INSIDE AND OUTSIDE MITERED CORNERS.

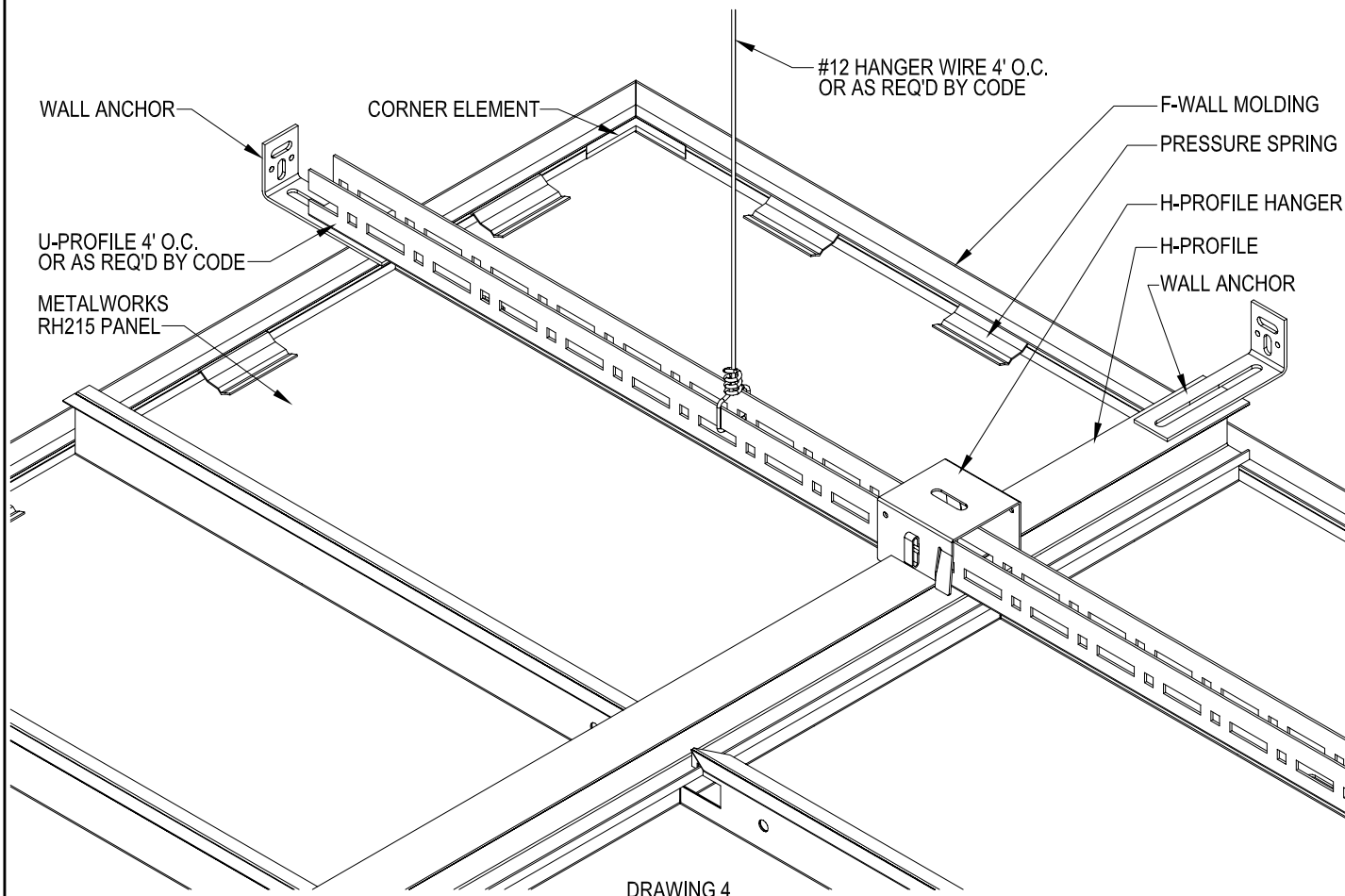
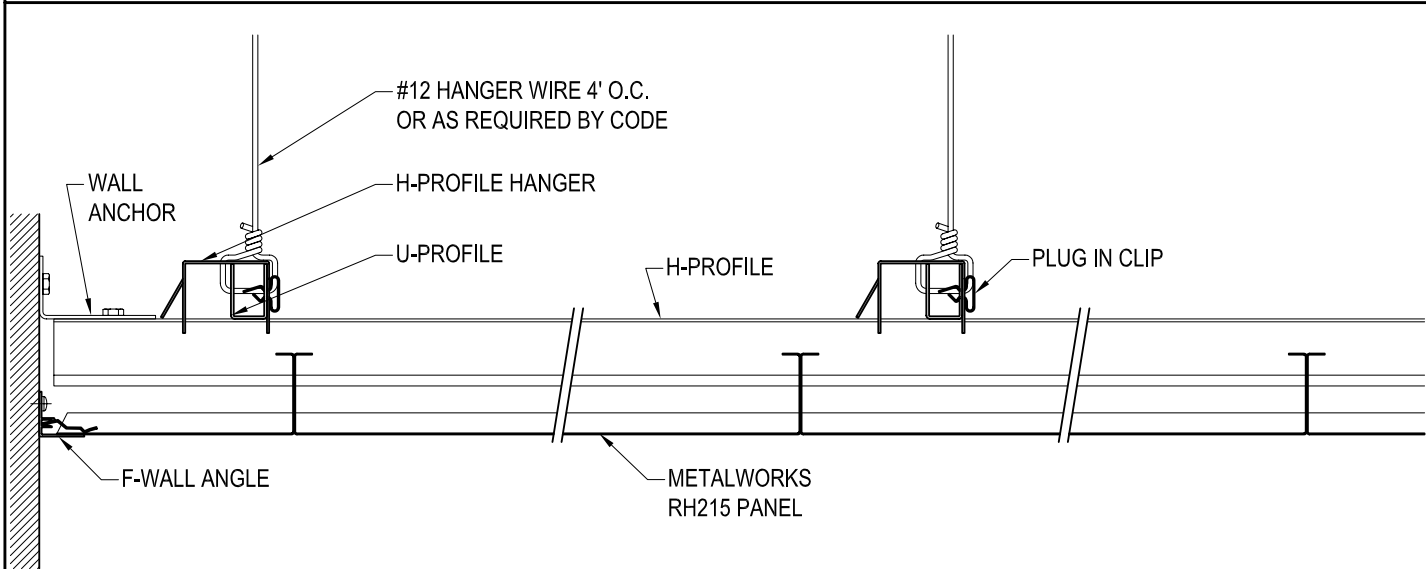

DRAWING 4

## RH-215 PERIMETER WALL TRIM OPTIONS

MOLDING MUST BE SECURELY FASTENED TO THE WALL EVERY 16" TO 24". USE F-MOLDING WALL ANGLE OR F-MOLDING SHADOW WALL ANGLE AROUND THE PERIMETER. INSERT A PRESSURE SPRING TO KEEP THE CUT EDGE TIGHT ON THE WALL MOLDING. USE THE SHADOW F-MOLDING TO CREATE A REVEAL BETWEEN THE WALL AND MOLDING. USE ARMSTRONG CHANNEL MOLDING #7835 AROUND THE PERIMETER. THE CUT EDGE OF THE PANEL WILL REST ON THE BOTTOM HORIZONTAL FLANGE. INSERT A #7835SC SPREADER CHANNEL TO KEEP THE CUT EDGE TIGHT ON THE WALL MOLDING.

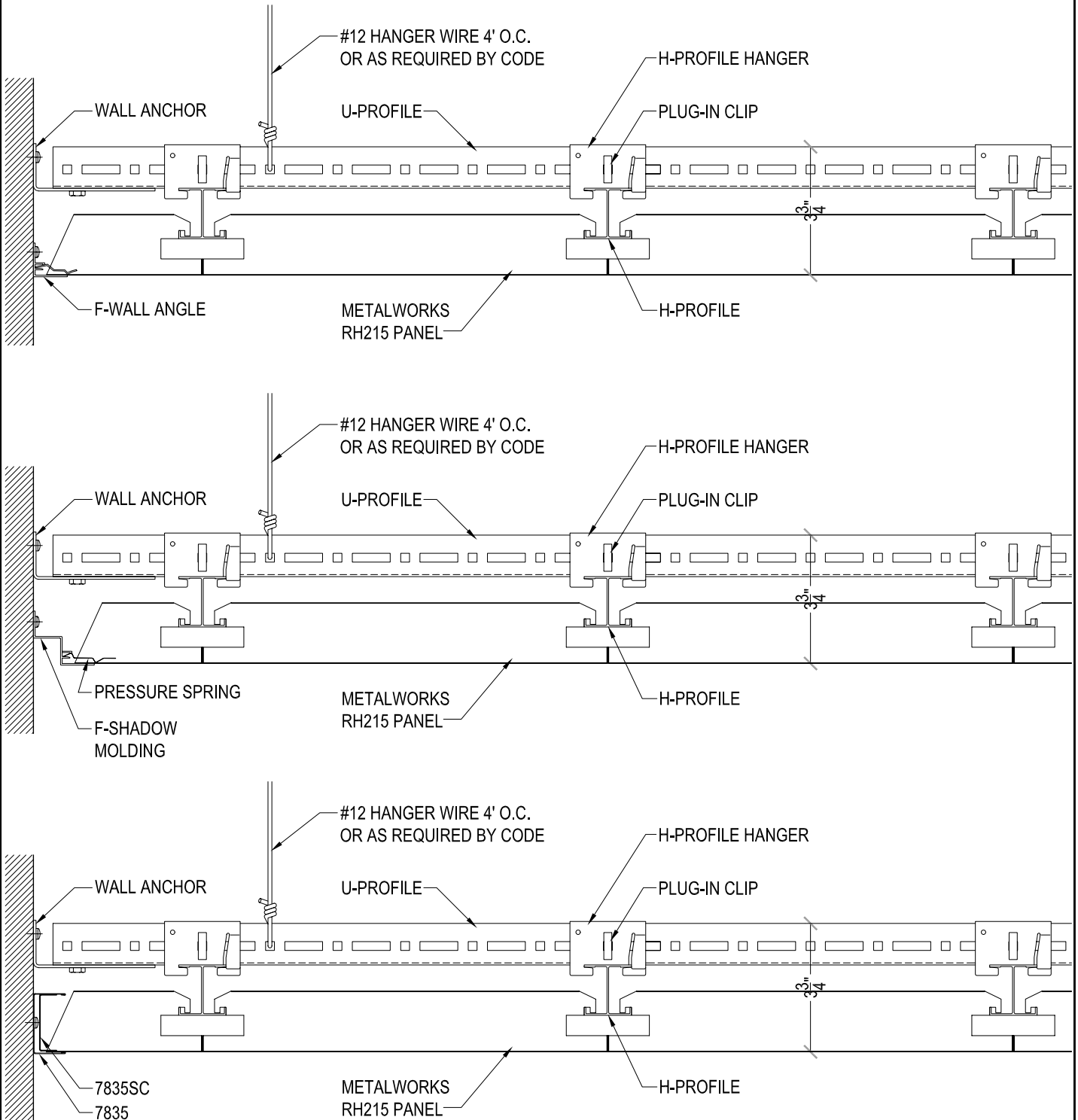

DRAWING 5

## INSTALLATION AND REMOVAL OF METALWORKS RH-215 PANELS

### INSTALLATION OF METALWORKS RH-215 PANELS

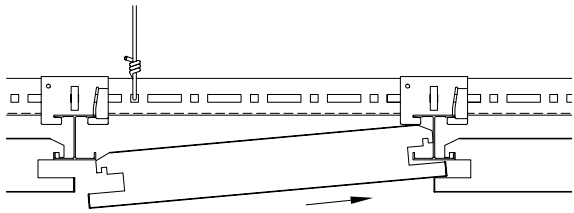

STEP 1) FULLY INSERT THE RIGHT SIDE OF PANEL ABOVE ADJACENT PANEL

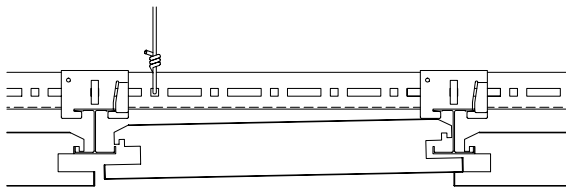

STEP 2) RAISE LEFT SIDE OF PANEL SO NOTCHED TAB IS OVER TOP OF H-PROFILE.

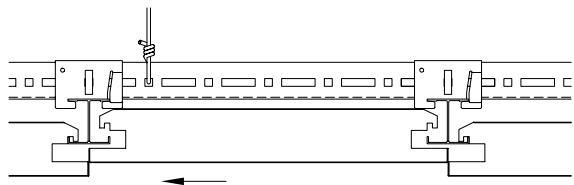

STEP 3) SLIDE RH-215 PANEL TO THE LEFT SO THAT THE NOTCHED TAB IS OVER TOP OF THE H-PROFILE

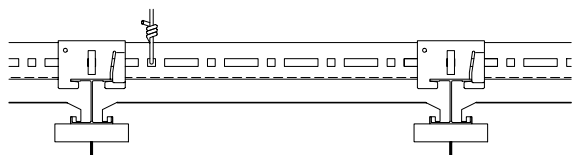

STEP 4) LOWER METALWORKS PANEL EVENLY ONTO H-PROFILE. CHECK PANEL(S) FOR PROPER ALIGNMENT.

### REMOVAL OF METALWORKS RH-215 PANELS

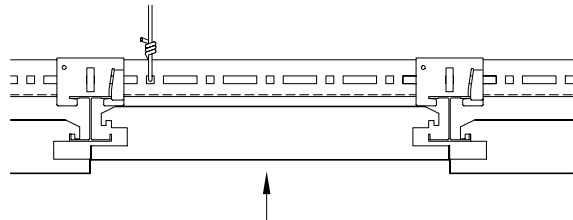

STEP 1) CAREFULLY LIFT PANEL EVENLY SO THAT THE NOTCHED TAB IS OVER TOP OF THE H-PROFILE

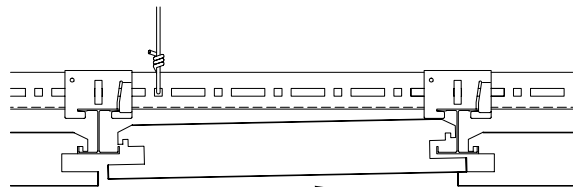

STEP 2) SLIDE DESIRED PANEL FOR REMOVAL TO THE RIGHT. SLIDE PANEL FACE INTO GAP BELOW H-PROFILE OF ADJACENT METAL WORKS PANEL. (CAREFUL NOT TO SCRATCH PANEL FACE). BE SURE THAT NOTCHED TAB ON LEFT OF METALWORKS PANEL IS CLEAR OF H-PROFILE.

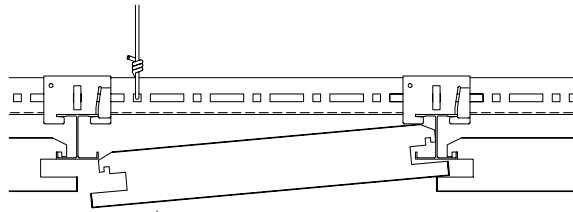

STEP 3) LOWER LEFT SIDE OF METALWORKS PANEL BELOW THE BOTTOM EDGE OF H-PROFILE.

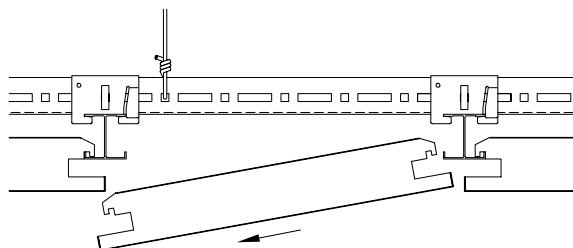

STEP 4) SLIDE METALWORKS PANEL TO LEFT PAST THE BOTTOM OF H-PROFILE ON RIGHT. LOWER PANEL PAST H-PROFILE ON RIGHT. MAKE SURE PANEL CLEARS H-PROFILE CAREFULLY.

DRAWING 6