



CEILING SYSTEMS

[Between us, ideas become reality.]®

METALWORKS™ Vector™ for Exterior Application Installation Instructions

1. GENERAL

1.1. Product Description

MetalWorks Vector items 9418U6A1WH2 (unperforated) and 9420U6A1WH2 (micro-perforated) are recommended for nonexposed exterior applications except in geographical areas with high concentrations of acid rain. Other colors are also available, including Effects™ Wood Looks Vector options.

1.2. Only these specific suspension system items and accessories should be used for wind uplift application

Prelude Main Beam	item #	7301G90
Prelude Cross Tee	item #	XL7321G90
Angle Molding	item #	HD7801G90
Brace Attachment Clip	item #	BACG90
Cross Tee Adapter Clip	item #	XTAC

1.3. This instruction sheet provides details for the proper application of these products in areas requiring resistance to wind uplift forces. Please refer to the standard MetalWorks Vector Installation Instructions (LA-295532) for general information regarding the installation of MetalWorks panels and the supporting suspension system or to the standard Effects Vector Installation Instructions (LA-297145) for general information on the installation of those specialty panels.

1.4. The details and descriptions provided in this document for field panels (those not in contact with the perimeter molding) depict the method used during independent testing conducted according to the "Standard Test For Uplift Resistance Of Roof Assemblies" UL580. The result of this test was a Class 90 rating. Perimeter details were evaluated using static hydraulic testing which was designed to simulate loads in excess of 105 LB/SF.

1.5. Armstrong is not licensed to provide professional architecture or engineering design services.

These drawings and descriptions show typical conditions in which the Armstrong product depicted is

installed. They are not a substitute for an architect's or engineer's plan and do not reflect the unique requirements of local building codes, laws, statutes, ordinances, rules and regulations (legal requirements) that may be applicable for a particular installation.

Armstrong does not warrant, and assumes no liability for the accuracy or completeness of the drawings for a particular installation or their fitness for a particular purpose. The user is advised to consult with a duly licensed architect or engineer in the particular locale of the installation to assure compliance with all legal requirements.

1.6. This document consists of four pages. All pages must be included in any application of these recommendations.

2. INSTALLATION OF THE WALL MOLDING

2.1. Product Description

The recommended molding is Armstrong HD7801G90 angle molding. This part is a 7/8" x 7/8" x 120" angle formed from G-90 hot dipped galvanized steel and capped with white painted aluminum.

2.2. Attachment should be by metal fasteners of a type and size appropriate for the mounting surface. This molding will bare the dead load weight of 1/2 of the area of ceiling extending from the wall to the nearest suspension system member. The Vector panels and grid weigh about 1.5 LB/SF. In addition to the dead weight, the molding must also resist negative (downward) pressure equivalent to the wind uplift class required for the application. Fasteners should be evenly spaced along the length of the molding and the maximum center spacing should not exceed 16".



3. INSTALLATION OF THE SUSPENSION SYSTEM

3.1. The recommended Suspension system consists of Armstrong Prelude main beam #7301G90, spaced 2' on center and XL7321G90 2' long cross tees, also spaced 2' on center. These components are fabricated from G-90 hot dipped galvanized steel for superior corrosion resistance, and are finished with a white painted aluminum cap.

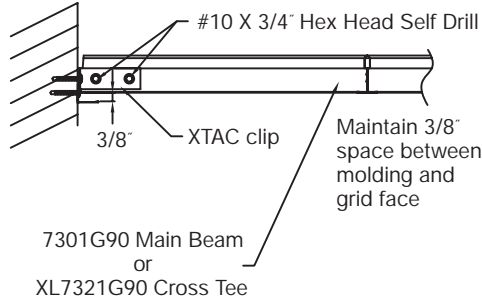

Section Detail AA

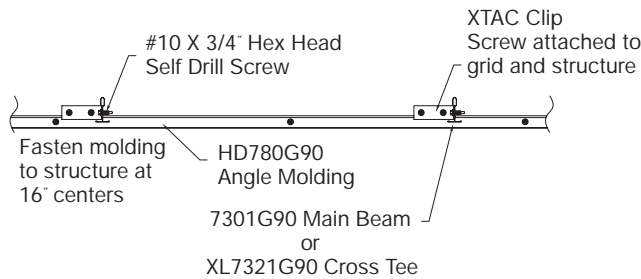

Section Detail CC

3.2. Notice that a space of 3/8" must be maintained between the wall molding and the face of the grid system. Temporary blocking may be inserted in this space to facilitate the installation of the grid.

3.3. Armstrong's XTAC clip may be used to secure the grid ends to the structure. Attachment of the clip to the grid should be by means of two #10 x 3/4" hex head self-drilling screws. Attachment to the structure shall be by means of metal fasteners of a type and size appropriate for the application, and capable of resisting the upward forces of the design load.

3.4. Hanger wires are of little consequence, as support for the mains will be by means of compression struts spaced at 2' centers. Wires may be used as required to install and level the grid system prior to the attachment of the compression struts. Hanger wires may remain in place or may be removed after the installation is completed.

4. INSTALLATION OF THE COMPRESSION STRUTS

4.1. Compression struts are required every 2 feet along the length of the main beams. The size and shape of the strut material must be designed to meet the requirements of the particular application. Independent testing was successfully conducted to Class 90 using 20-gauge steel stud (CSJ flange measuring 2-1/2" deep, with a 1-5/8" flange width) at a length of 30".

4.2. Struts are to be placed adjacent to the intersections of the cross tees with the main beams. Additionally, struts must be installed at the location of the main beam splices. These struts shall be secured by screws placed on either side of the splice detail.

4.3. Note that the bottom end of the strut should extend below the bottom of the bulb of the main beam, but not so much so as to interfere with the placement of the screws that connect the main to the clip.

4.4. The top end of the strut is fashioned by cutting through the flanges of the stud and folding over a short horizontal leg of approximately 3". The top end of the strut shall be attached to the structure by means of at least two metal fasteners of a type and size appropriate for the application.

4.5. Attachment to the grid system shall be by means of the Armstrong BACG90 clip. Two #10 x 3/4" hex head self-drilling screws shall connect the clip to the main beam and two shall connect the clip to the strut.

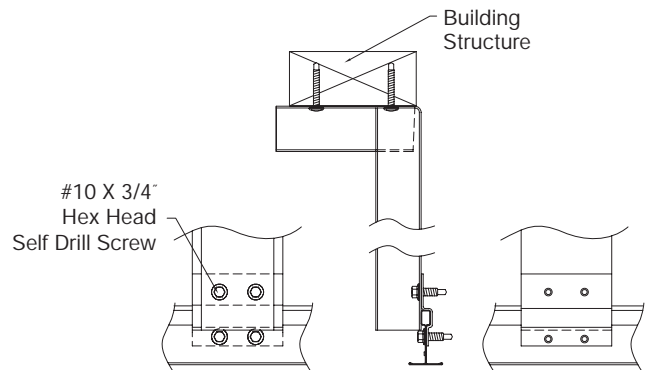

Compression Strut Detail

4.5.1. Correct placement of these screws is important. They must be inserted through the strut and the grid and into the clip. Begin by clamping the BACG90 clip in position, then drill through the strut and main beam at the four pilot hole locations. The self-drilling screws may now be inserted through the drilled holes.

5. INSTALLATION OF THE BORDER PANELS

5.1. Consult the standard Installation Instructions for MetalWorks Vector (LA-295532), Effects Vector (LA-297145) and the MetalWorks Cutting Instructions (LA-295518) for information regarding sizing and cutting of the panels.

5.2. Perimeter panels must be secured to resist both the upward forces at the wall angle and lateral forces that may dislodge the panel edge detail from the grid system.

5.3. Begin by properly positioning the panel into the grid opening, then fold the border tabs over the grid flanges and secure with #6 x 7/16" self-drilling screws inserted through the border tabs and the grid flange.

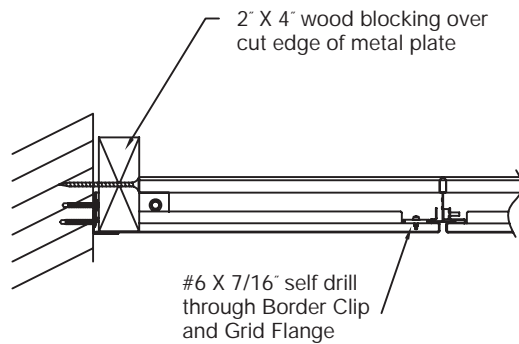

5.4. Secure the cut side by placing a 22-3/8" long piece of 2" x 4" dimensional lumber over the panel edge. Secure the block to the structure with a minimum of two metal fasteners of a size and type appropriate for the application. This blocking must be capable of resisting the upward forces anticipated by the design criteria.

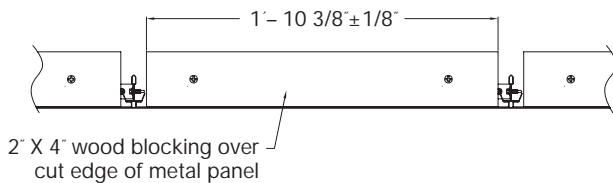

5.5. The installation described to this point was successfully tested to a rating of Class 60. However, the extreme forces encountered at the Class 90 level require the placement of additional blocking over the ends of the grid members. This blocking, also cut from 2" x 4" dimensional lumber, should be 12" long and placed as shown in the drawing below. Secure each section with a minimum of two metal fasteners of a type and size appropriate for the application.

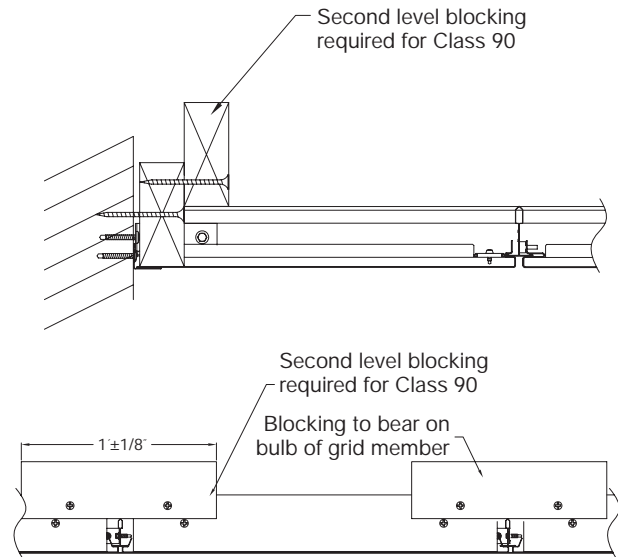

6. INSTALLATION OF CORNER PANELS

6.1. Corner panels, or any other perimeter panel that has two or more factory edges cut, will require the addition of a plywood reinforcement panel. This panel is to be cut from 3/4" CDX grade plywood. Secure the plywood to the bottom of the 2" x 4" perimeter blocking. The entire bracing assembly is then attached to the building structure as a unit.

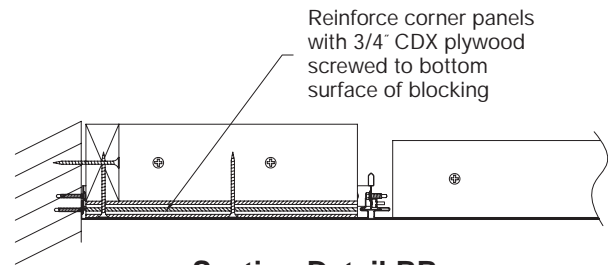

7. INSTALLATION OF FIELD PANELS

7.1. Full size panels are installed as described in the standard installation instructions. No special techniques are required for applications through a rating of Class 90. Full accessibility through these full size panels is maintained.

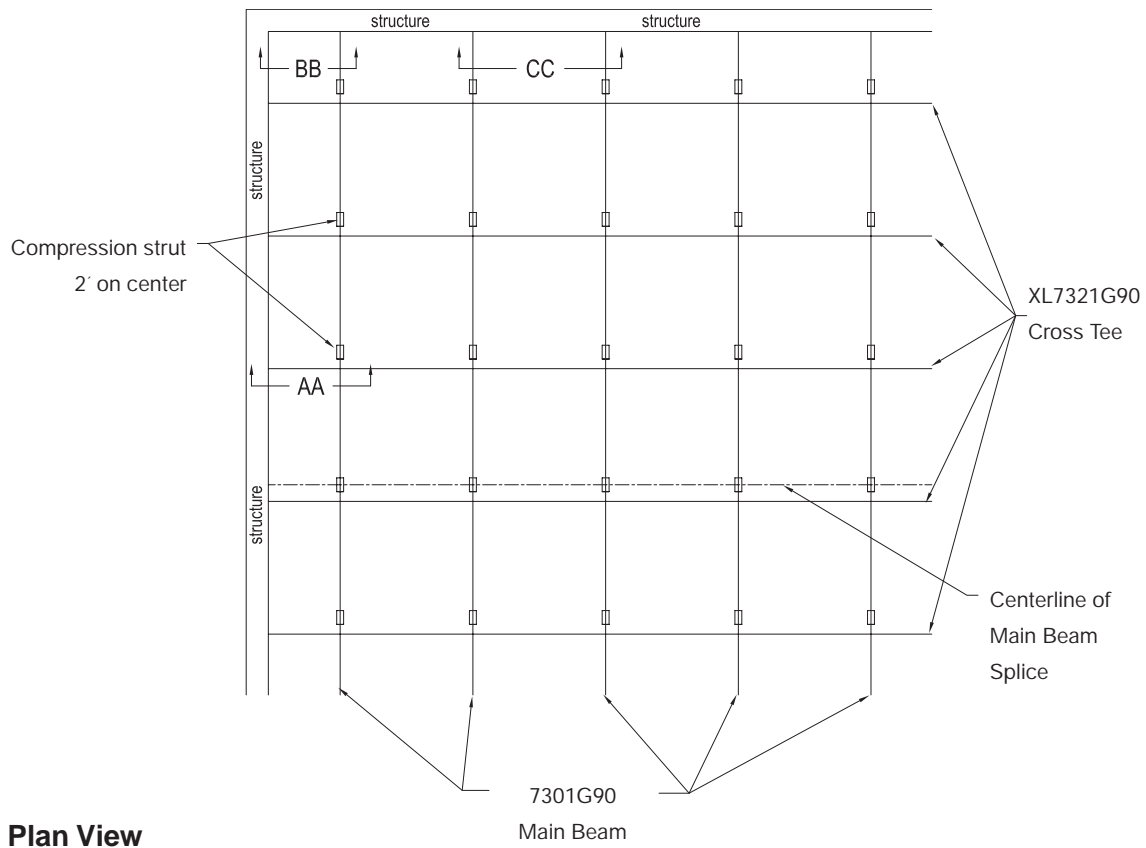

MORE INFORMATION

For more information, or for an Armstrong representative, call 1 877 ARMSTRONG.

For complete technical information, detail drawings, CAD design assistance, installation information and many other technical services, call TechLineSM services at 1 877 ARMSTRONG or FAX 1 800 572 TECH.

For the latest product selection and specification data, visit armstrong.com/ceilings.